

# Elementary 2

Year 2 Book 2

E2 Year 2 Book 2

Preparing for the Kingdom of Heaven

USGA

## *Preparing for the Kingdom of Heaven*



Teacher's Guide and Student Worksheets

# ELEMENTARY 2 YEAR 2 BOOK 2

## PREPARING FOR THE KINGDOM OF HEAVEN

### INTRODUCTION

The main objectives for this quarter are:

- To introduce to students the concept of the church.
- To go in-depth about prayer and teach students several important prayers in the Bible.
- To emphasize to students that we are in the end times, and that it is important to be prepared.

### LESSON INDEX

Lesson 1	My Church and I	1-12
Lesson 2	I Can Help My Church	13-26
Lesson 3	Seek to Do God's Will	27-42
Lesson 4	What Is Prayer	43-54
Lesson 5	The Lord's Prayer (Part 1)	55-65
Lesson 6	The Lord's Prayer (Part 2)	66-82
Lesson 7	Four Great Prayers in the Old Testament	83-95
Lesson 8	Jesus' Great Prayer	96-106
Lesson 9	The End Time Is Near	107-117
Lesson 10	The Parable of the Ten Virgins	118-132
Lesson 11	The Parable of the Great Banquet	133-146
Lesson 12	The Second Coming of Jesus	147-157
Lesson 13	Review	158-162

# LESSON GUIDE

The E2 lessons can be separated into 3 sections with several subsections that, as a whole, are aimed to provide a comprehensive Bible study of the selected topic.

The first section is an **introduction** to the lesson and includes the Objectives, Memory Verse, Prayer, Overview, Background Knowledge for the Teachers, and Reaching Out to Your Students sections. This section is meant for the teacher to study while preparing the lesson so that the teacher will know in which direction to guide the students while teaching.

The second section includes the **main content** of the lesson that will be taught to the students during class. Here the teacher will find the Opener, Vocabulary, Bible Discovery & Spiritual Teaching, Linking to the Ten Basic Beliefs, Check for Understanding, Life Application, and Activity sections.

Lastly, the students will have a homework assignment to take home and complete after class as a **review** of the lesson. The students are expected to bring back the homework assignment to the next class completed and with a parent signature.

\*\*\*\*

This lesson guide will list each subsection and explain its purpose, as well as how teachers should use the information in that subsection.

## I. Introduction to the Lesson

### 1. Objectives

These are the objectives that the lesson aims to fulfill. The teacher should always remember to reinforce ideas and teachings that will fulfill these objectives.

### 2. Memory Verse

The teacher should go over the memory verse at the beginning of class and ask the students to have it memorized by the end of class.

### 3. Prayer

Go over these points with the students before beginning prayer so that they will know what they should pray for, in addition to their own prayer requests.

### 4. Overview

A simple lesson overview that emphasizes the important points of the lesson.

### 5. Background Knowledge for Teachers

Relevant biblical background knowledge that can aid the teachers in understanding the lesson.

### 6. Reaching Out to Your Students

This section provides an insight into how the students might react to the lesson and how to help the students understand the lesson.

## II. Main Lesson Content

### 1. Opener // 5 Minutes

The purpose of the Opener is to ease the students into the lesson by bringing up relevant topics that will relate to the Bible study. This will give students time to calm down before the teacher goes into the main content.

### 2. Vocabulary

The vocabulary is provided to explain some of the more difficult terms. The teacher can choose to go over the terms before beginning the Bible study or as the terms come up during the lesson.

### 3. Bible Discovery & Spiritual Teaching // 30-35 Minutes

This is the main section of each lesson. It will provide an in-depth study of the selected topic and the students will also be provided worksheets to fill in as the teacher conducts the lesson. The teacher should look at the worksheets while preparing the lesson and print out a copy to use as an answer key during class. The aim of the worksheets is to keep the students focused and to let them actively participate instead of passively listen.

### 4. Linking to the Ten Basic Beliefs // 2-5 Minutes

It is important to tie each lesson back to the Ten Basic Beliefs to reinforce the students' knowledge of the Beliefs; therefore, this section will briefly tie back the lesson to the Basic Belief to which it relates.

### 5. Check for Understanding // 5 Minutes

This section tests the students' comprehension of the teachings they just learned in the Bible Discovery & Spiritual Teaching section.

### 6. Life Application // 10 Minutes

The Life Application section aims to make the lesson content more life applicable and will allow the students to relate the lesson's teachings to events that happen in their daily lives. The goal is to give the students a chance to apply what they have learned in the lesson to their daily lives.

### 7. Activity // 10-15 Minutes

Each lesson will include one or two activities that relate back to a teaching or story in the Bible Discovery & Spiritual Teaching section.

## III. Homework Assignment

Students are to take this home and return it the next week completed. There are four elements to the homework assignment: (1) Bible reading and prayer chart, (2) what they learned from the Bible, (3) memory verse, (4) and a lesson-specific assignment. The Bible reading and prayer chart is provided to track the students' progress during the week. In addition, the students will have to write down the memory verse and two things they learned from the Bible during that week. The last part of the homework assignment is specific to that week's lesson. It is advised that the students obtain a parent signature to make sure that the parents know what the students are learning each week.

## IV. Suggested E2 Class Timeline

5 min.	Opening Prayer
5 min.	Opener
30-35 min.	Bible Discovery & Spiritual Teaching
2-5 min.	Linking to the Ten Basic Beliefs
5 min.	Check for Understanding
10 min.	Life Application
10-15 min.	Activity
5 min.	Ending Prayer

**Total:** 1 hr. 12 min. - 1 hr. 20 min.



# UNDERSTANDING YOUR STUDENTS

## Upper Elementary/Primary Stage (Ages 9-11)

Characteristics	Pedagogic Application
<b>Body</b> 1. Generally healthy 2. Active 3. Begin to step into puberty stage, get hungry easily 4. Girls become taller than boys toward later stage  5. Increase in stamina	Encourage healthy eating habits Can plan for outdoor activities/fellowships sometimes Prepare snacks if their time in church is especially long Teach them how God values their character; build healthy self-esteem Have challenging and difficult activities
<b>Mind</b> 1. Like to collect things 2. Very creative 3. Begin to think and deduce 4. Like asking questions 5. Have good memory 6. Limited understanding of profound/abstract matters 7. Increased reading ability and comprehension	Include more challenging activities Provide creative and Bible-related activities Use pedagogy that enhance critical thinking Provide satisfactory and biblical answers Encourage memorization of Bible verses Need to explain abstract terms Nurture interest in reading the Bible/Christian materials
<b>Mood</b> 1. Express emotions easily  2. Short-tempered; lose patience easily  3. Like humor 4. May have feelings of withdrawal (may be scared, anxious, etc.)	Provide routines that help students to quiet down and get ready to focus Teach students how to control emotions and appropriate ways to express emotions Include some humor while teaching Show more care and concern; teach them the importance of relying on God
<b>Social Skills</b> 1. Loyal toward friends of the same age more than parents or teachers 2. Like to make friends of the same gender 3. Loyal to groups or teams 4. Enjoy competitive games or activities 5. Like to joke around; may make fun of others  6. Admire favorite teachers and classmates	Encourage friendship, but stress the importance of respecting parents and elders Can separate into girls and boys for group discussion Teach students how to discern negative peer pressure Provide competitive games where everyone can participate Encourage healthy jokes without hurting others' feelings; teach mutual respect Suggest some Christian biographies for students to read; set good examples for the students; share your personal faith and convictions
<b>Spirituality</b> 1. Express maturity in accepting the way of salvation  2. Worship heroes  3. Can study the Bible and pray 4. Can accept a deeper level of Bible teaching 5. Show concern over the souls of others	Talk about salvation seriously; share with them how God changed your life Teach stories of Bible heroes and spiritual characters; provide good Christian living examples Encourage daily spiritual cultivation (pray/read the Bible) Help the students to discover the teachings from the Bible Encourage students to pray and/or bring family members or friends to the Lord

## MEMORY VERSES

1. "And the continued steadfastly in the apostles' doctrine and fellowship, in the breaking of bread, and in prayers." (Acts 2:42)
2. "This is My commandment, that you love one another as I have loved you." (John 15:12)
3. "Rejoice always; pray without ceasing; in everything give thanks, for this is the will of God in Christ Jesus for you." (1 Thessalonians 5:16-18)
4. "Continue earnestly in prayer, being vigilant in it with thanksgiving." (Colossians 4:2)
5. "Be anxious for nothing, but in everything by prayer and supplication, with thanksgiving, let your requests be made known to God." (Philippians 4:6)
6. "For if you forgive men their trespasses, your heavenly Father will also forgive you. But if you do not forgive men their trespasses, neither will your Father forgive your trespasses." (Matthew 6:14-15)
7. "Now this is the confidence that we have in Him, that if we ask anything according to His will, He hears us." (1 John 5:14)
8. "Let us therefore come boldly to the throne of grace, that we may obtain mercy and find grace to help in time of need." (Hebrews 4:16)
9. "Watch therefore, and pray always that you may be counted worthy to escape all these things that will come to pass, and to stand before the Son of Man." (Luke 21:36)
10. "Watch therefore, for you know neither the day nor the hour in which the Son of Man is coming." (Matthew 25:13)
11. "Behold, I stand at the door and knock. If anyone hears My voice and opens the door, I will come in to him and dine with him, and he with Me." (Revelation 3:20)
12. "Therefore you also be ready, for the Son of Man is coming at an hour you do not expect." (Luke 12:40)

# LESSON 1

## MY CHURCH AND I

### OBJECTIVES

1. To understand what a church is.
2. To be thankful that we are a part of the body of Christ.
3. To understand the roles and responsibilities of a pastor, deacon, and elder.
4. To encourage students to respect the pastors as those chosen by God to lead the church.
5. To understand what it means to have fellowship.

### MEMORY VERSE

“And they continued steadfastly in the apostles’ doctrine and fellowship, in the breaking of bread, and in prayers.”

(Acts 2:42)

### PRAYER

1. In the name of Jesus Christ, we pray. Thank You, Lord, for gathering us here this Sabbath so we can worship You.
2. Please give us the wisdom to understand that we are part of the body of Christ.
3. We are grateful for the blessing to be part of this big family in Christ, and ask that You give us the strength to do our best when serving You.
4. Finally, we ask that You guide today’s class so that we can learn more about those who serve You.



### Overview

#### 1. Bible Discovery

- Practices of the Early Church
- What "Church" Means for Us Today
- Ministers of the Early Church
- Ministers in Our Church Today

#### 2. Linking to the Ten Basic Beliefs—One True Church

#### 3. Life Application

- Fellowship
- We Can Help the Church
- Testimony: The Blessings of Fellowship

#### 4. Activity—We Are All One Family



### Background Knowledge for Teachers

#### Power from the Holy Spirit

Jesus promised His disciples that they would receive power to bear witness of Him after receiving the Holy Spirit. Notice the progression:

1. They received the Holy Spirit.
2. He gave them power.
3. They witnessed with extraordinary results.

Power from the Holy Spirit is not limited to strength beyond the ordinary—it involves courage, boldness, confidence, insight, ability, and authority.

#### Tongues of Fire

Since the first time God poured out His Holy Spirit on the day of Pentecost (Acts 2), believers who receive the Holy Spirit have been able to speak in tongues. Speaking in tongues is audible, and the person praying often has movements of the body, which can be seen. Jesus’ disciples said that they, as well as observers, could “see and hear” the pouring out of the Holy Spirit (see Acts 2:33; also Acts 10:45-47).

If the Holy Spirit dwells in you, you can speak in tongues whenever you pray. Speaking in tongues is not a one-time experience only. Through prayer in tongues, “the Spirit Himself makes intercession for us with groanings which cannot be uttered” (Rom 8:26).

When you ache so deeply that mere words cannot convey your pain, or when a “thank you” hardly expresses your appreciation to God, the Holy

Spirit prays for you, replacing your earthly words with a spiritual language. You will find prayer in the Spirit more satisfying because the Holy Spirit enables you to know God's will and truth. He will express your needs more effectively than human language can.

The word "fire" in "tongues of fire" symbolizes God's purifying presence, which burns away the undesirable elements of our lives and sets our hearts aflame to ignite the hope of God in others.

### Breaking of Bread

"Breaking of bread" refers to communion services that were celebrated in remembrance of Jesus and were patterned after the last supper that Jesus had with His disciples before His death (Mt 26:26-29). It also refers to the sharing of bread, i.e., having meals together.



## Reaching Out to Your Students

As your students enter their later elementary school years, peer pressure becomes an increasingly crucial factor in their decisions, and may either be a positive or negative influence on their attitude toward the church. While some students come to church without much thought simply because their parents bring them, others come for social reasons: they come because their friends are at church. This lesson stresses the need for Christian believers to gather for education, fellowship, and worship.

Children at this age also want to earn recognition by producing something and gaining satisfaction as a result. The Bible, on the other hand, emphasizes humility and working for God in secret. As a result, they may not enjoy coming to church as much, or put less effort into their duties. During this lesson, try to help your students understand that they are in church because God brought them there for His purpose; they are a necessary part of His body, and each time they don't attend church, God misses them.

In keeping with the theme of serving God as one body, this lesson also focuses on the responsibilities that our church ministers have. Try to help your students learn to appreciate their work and the kinds of burdens they have to bear as shepherds of the church.



## Opener

*5 Minutes*

### "Missing Limbs"

This warm-up activity will attempt to demonstrate to your students what it really means to be one body in Christ, and how important each of them are within the church. Begin by assigning each student a "missing limb" (e.g., their dominant hand/arm, a foot/leg, or even one of their eyes). They aren't allowed to use this part of their body for the next few minutes. Then, assign them various activities that are obviously difficult without the use of those body parts. For example, folding a piece of paper, fetching an item from across the room, or catching a ball.

Explain to your students that each of us are a part of the body of Christ, and that each of us are just as valued or important as each part of our own bodies. We may be a foot, a hand, or an eye, but each of us are vital components in the church, each with our own roles prepared for us by God.

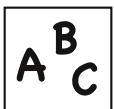

## Vocabulary

**Pentecost:** The Pentecost has many names in the Bible (the Feast of Weeks, the Feast of Harvest, and the Latter Firstfruits). Celebrated on the fiftieth day after Passover, the Pentecost is traditionally a joyous time of giving thanks and presenting offerings to God for the new grain of the summer wheat harvest in Israel.



## Bible Discovery & Spiritual Teaching

30-35 Minutes

In our lesson today, we're going to learn more about how the idea of a "church" came about, and about some of the responsibilities our church ministers have today. In order to study this, we're going to take a look at the very beginning—how the church began.

Did you know that in biblical times, people didn't worship in church buildings? They visited temples, or worshipped at altars instead. So how did the idea of gathering in one building come about? Let's open our Bibles and turn to Acts, chapter 2.

Before we begin reading, do you remember what happened to the disciples after Jesus ascended to heaven? He told them to wait for the Helper who would come. So they obeyed and waited, gathering in Jerusalem and praying together. It was during one of these gatherings that the Day of Pentecost occurred. The Holy Spirit came down for the very first time!

But what does the Holy Spirit have to do with the beginnings of church worship? Let's read verses 1-8. The sight and sound of the Holy Spirit gathered many, many people around the building in which the disciples prayed. The people had gathered—it was now time to preach to them! Let's continue by reading verses 14-21 and 37-41. That day, timid Peter who denied Jesus three times stood and, with the power of the Holy Spirit, preached to and converted three thousand people! Can you imagine such a sudden increase in the number of Jesus' followers? It was with this huge company of people that the idea of a church began.

### Practices of the Early Church

The early church was very different from what we might imagine, because the peoples' lives during that time were unlike ours today. They lived simple lives in harmony with one another, but they didn't have one big building in which they could gather. Instead, they met at different houses to worship together. Let's read Acts 2:44-47.

#### FOR TEACHERS

Have the students turn to the Bible Discovery worksheet and fill in the first section. Answers have been provided.

Let's list what these verses say the early believers did.

- Shared their belongings ("had all things in common")
- Sold their belongings to share among the needy
- Broke bread together daily
- Had gladness and simplicity in their hearts

- Praised God
- Gained favor among the people
- Continued to grow in number

Later on, at Antioch, a thriving church was founded, with both the Jews and the Gentiles as members. This is when the believers were first called "Christians" (Acts 11:26). Paul said we "are no longer strangers and foreigners, but fellow citizens with the saints and members of the household of God." We are His temple, "built together for a dwelling place of God in the Spirit" (Eph 2:19, 22).

### What "Church" Means for Us Today

A church is made up of its members, not the building itself. "Church" comes from a Greek word that means, "called out assembly." The Jews had been "called out" from the nations to be God's special people. Today, the church is made up of people who believe in Jesus and follow Him obediently. Most importantly, the church comprises people who were bought with the blood of Jesus Christ (Acts 20:28). The Bible uses different imagery to help us understand what Jesus' church is like.

#### FOR TEACHERS

Have your students turn back to their worksheets and fill in the second section. The answers have been provided.

(1 Corinthians 12:12) *"For as the body is one and has many members, but all the members of that one body, being many, are one body, so also is Christ."*

(Romans 12:5) *"So we, being many, are one body in Christ, and individually members of one another."*

(Matthew 12:49-50) *"And He stretched out His hand toward His disciples and said, 'Here are My mother and My brothers! 50 For whoever does the will of My Father in heaven is My brother and sister and mother.'"*

### The Church Is One Body

According to the verses we just looked up, the Bible describes the church in two ways. First, the church is one body. People who believe in Jesus are linked together, as parts of a body are linked together. Each person has a special job in the body, just like the arms, legs, and other parts of our body. When we view the church as a body, it helps us realize that each of us is important, and that each of us has a different way to serve God and other people.

### The Church Is One Family

The second way the Bible describes Jesus' followers is by



saying we're a family. Christians in the New Testament era called each other brothers and sisters. This was because they loved each other as such (1 Tim 5:1-2). The church, then, is made up of people who are family. We will not be alone if we take time to become friends with others in church. Even though we are not blood related, the blood of Jesus Christ has washed us all. We should love and support each other as a spiritual family.

### Ministers of the Early Church

We just learned that, as part of the body of Christ, each of us has our own role as different "limbs." One of these roles is that of a pastor who leads the church. One of Jesus' favorite metaphors for spiritual leaders was that of a shepherd—a person who tends God's flock. In fact, the definition of the word "pastor" is "to shepherd." The flock that the pastor must shepherd refers to the church members. A shepherd must lead, feed, nurture, comfort, and protect the sheep. These are all responsibilities that a pastor—or a minister as we sometimes call them—must shoulder.

#### Timothy

To better understand what it means to be a minister, let's first look at a biblical example. Some of you may know of Timothy, a young disciple who learned about ministering a church from Paul. The first time we hear of Timothy, the Bible describes him as someone who was "well spoken of by the brethren" at Lystra and Iconium (Acts 16:2). What do you think it means to be "well spoken of"? Just from this statement, what kind of a person do you think Timothy was? [Allow students to discuss and give their own answers.]

Overall, I think we can agree that Timothy was a good Christian who lived according to Jesus' teachings. It was because of this characteristic that Paul chose to bring him along to help him in his travels (v. 3). Now, Timothy became so important a worker that Paul actually wrote two letters addressed solely to him.

We don't want to just study Timothy's characteristics, though. We want to examine what kind of responsibilities he had to shoulder. Let's turn to a few verses together and list out some of the commands Paul gave to him.

#### FOR TEACHERS

Once again, have your students turn to their worksheets and work as a group to fill out the appropriate section. Answers have been provided.

1 Timothy 1:3-4; 6:20 – *Guard the church members against false doctrine.*

1 Timothy 1:18 – *Wage the good warfare.*

2 Timothy 1:6 – *Stir up the gift of God (rely on the Holy Spirit).*

2 Timothy 2:2; 4:2 – *Teach the gospel to faithful men, convince, rebuke, and exhort.*

2 Timothy 2:3 – *Endure hardship.*

2 Timothy 4:5 – *Be watchful and endure.*

### Ministers in Our Church Today

Just like Timothy pastored the Ephesian church, we also have ministers who pastor our church today. Let's read Ephesians 4:11-13. This verse talks about how God has chosen some people to be apostles, prophets, evangelists, pastors, and ministers. So what is the purpose of pastors according to this verse? To equip the saints, to engage in the work of the ministry, and to edify the body of Christ.

#### FOR TEACHERS

Have students turn to the worksheet and fill in the blanks below as you go over them. Make sure the students have filled in the blanks before moving on.

Let's now turn to Acts 20:28. Pastors also need to be "overseers" of the flock, to shepherd the members of the church by "feeding" them with spiritual food.

Can you think of some of the things your pastor has done for your church? These are some of the roles and responsibilities of our church ministers:

- Evangelism (Mt 28:19)
- Administering the sacraments (Acts 8:38)
- Teaching and preaching (2 Tim 4:2)
- Shepherding God's sheep (Jn 10; Ezek 34:2)

It all comes to this: the pastor is here to help give understanding of God's Word, and exhort the people to be like God in speech and in action. Pastors are not business employees or hired hands, but those called to be God's holy servants for our benefit. How many of you pray for our local ministers? They have many difficult responsibilities that they have to shoulder, so let's remember to keep them in our prayers every day!



## Linking to the Ten Basic Beliefs

2-5 Minutes

### One True Church

As the true church, we are one body, chosen by God to fulfill His purpose. Because we are His body, we ought to move as one, working together and treating each other as brothers and sisters with love. Although it may be difficult because many members are still strangers to us, we should do our best to get to know one another through fellowship and worship. It is also important to remember that as one body, each of us has our individual responsibilities, given especially to us by God Himself. We must always remember that He chose us specifically for His purpose, and if ever we decide not to attend church, or to skip on our duties, Jesus always misses us.



## Check for Understanding

5 Minutes

- 1. What special event occurred when the apostles gathered in Jerusalem and prayed together? What do we call this day?** The Holy Spirit came down for the first time. The Day of Pentecost.
- 2. Name three things the early believers did together.** They shared all they had, sold their belongings to give to the needy, broke bread together daily, had gladness and simplicity in their hearts, praised God, gained favor among the people, and continued to grow in number.
- 3. What are two ways the Bible describes the church?** The church is one body and one family.
- 4. What does "pastor" mean? Who is the flock?** It means to shepherd. The members of the church are the flock.
- 5. How does the Bible first describe Timothy?** He was "well spoken of by the brethren."
- 6. Name two duties of our church ministers today.** They must evangelize, administer the sacraments, teach and preach, and shepherd God's sheep.



## Life Application

10 Minutes

### 1. Fellowship

[Hand out Life Application Worksheet #1 to the students and keep a copy for yourself to reference. Answers have been provided below.]

- Colossians 1:18 says, "He is the head of the body."
- Let's read 1 Corinthians 12:14-27.
  - Who gave the members their various functions? (v. 18)
  - What bad attitudes can lead to disharmony in the body of Christ? (vv. 15-16, 21)
  - Why are there no unnecessary functions (members) in the body? (v. 20-22)
- Answers may vary. If time allows, you may ask students to share their drawings.

### 2. We Can Help the Church

[Hand out Life Application Worksheet #2 to the students and keep a copy for yourself to reference. Ask students to read the scenarios, and then ask them to write down what they would do in that scenario. After, choose some volunteers to share their answers with the class. Suggested answers have been provided.]

- Haley should introduce herself to the family. Then, she could offer to show the children, or even the entire family, around church and bring them to see the RE classrooms after eating lunch with them.
- Billy should ask the student to stop running and come back to clean up the pencils and books. Then, he should tell all the E1 students that the church is not a playground, and that it is important to respect church property.

### 3. Testimony: The Blessings of Fellowship

[Hand out Life Application Worksheet #3 to the students and keep a copy for yourself to reference. Ask the students to take turns reading the testimony, and then go over the questions as a class.]

#### Questions to Think About

- 1. How did the fellowship impact this brother's life?** The people in the fellowship made him feel like he wasn't alone in the new environment. They made him feel like there were people who understood him and who cared about him.
- 2. What do you think his life would have been like if he had not joined this fellowship?** He would have been very lonely and possibly tempted to follow his school friends in what they were doing. He might even have gotten lost in his journey of faith.
- 3. Do you have a fellowship in your area? Please share what it's like.** Allow students to share. If they don't have anything to share, share about your own fellowship if you have one.



## Activity

### We Are All One Family

10-15 Minutes

**Objective:** To help the students remember that in church, we are one family, and that each family member plays an important part.

#### Materials

- Construction paper
- Photos of each student, either prepared beforehand or printed the day of, if you have a photo printer available
- Scissors
- Tape

#### Instructions

For this activity, we will create a bulletin board decoration for the classroom.

1. Take a photo of each of the students and print them out.
2. Give the students colorful construction paper.
3. Ask them to create a church with a big banner that says, "In Jesus Christ, We Are All One Family."
4. Have them tape their photos inside the church.

The photos will serve as reminders that we are all in God's church together, and that each one of us is an important part of the church.

#### HOMEWORK ANSWER KEY

1. True
2. False; three thousand
3. The early believers shared all they had, sold their belongings to give to the needy, broke bread together daily, had gladness and simplicity in their hearts, praised God, gained favor among the people, and continued to grow in number.
4. The church is one body and one family.
5. It means to shepherd. The members of the church are the flock.
6. He was "well spoken of by the brethren."
7. Our church ministers must: evangelize, administer the sacraments, teach and preach, and shepherd God's sheep.



### MY CHURCH AND I

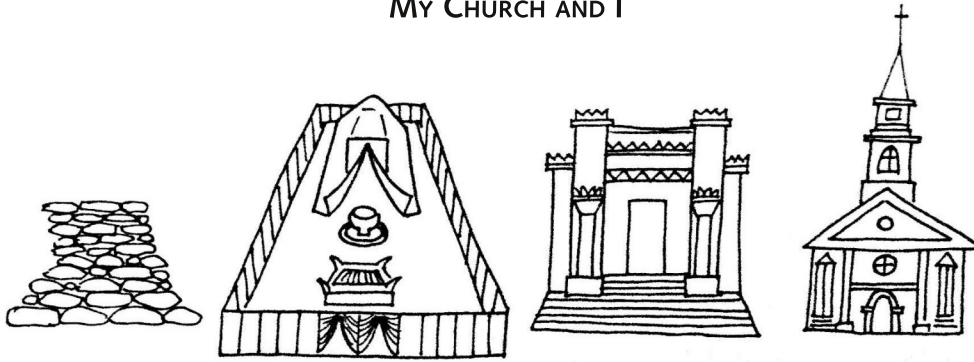

#### Practices of the Early Church

Open your Bibles to Acts 2:44-47 and try to list all of the practices of the early church members in the box below.

#### What "Church" Means for Us Today

Look up the following verses and write them below.

**1 Corinthians 12:12**

---

---

---

**Romans 12:5**

---

---

---

**Matthew 12:49-50**

---

---

---

**Ministers of the Early Church**

What kinds of responsibilities did Timothy have as a pastor? Turn to the following verses and write them down.

- 1 Timothy 1:3-4; 6:20 \_\_\_\_\_
- 1 Timothy 1:18 \_\_\_\_\_
- 2 Timothy 1:6 \_\_\_\_\_
- 2 Timothy 2:2; 4:2 \_\_\_\_\_
- 2 Timothy 2:3 \_\_\_\_\_
- 2 Timothy 4:5 \_\_\_\_\_

**Ministers in Our Church Today**

- 1. Pastors also need to be \_\_\_\_\_ of the \_\_\_\_\_, to \_\_\_\_\_ the \_\_\_\_\_ of the \_\_\_\_\_ by \_\_\_\_\_ them with spiritual food.
  
- 2. Some of a minister's duties consist of \_\_\_\_\_, \_\_\_\_\_ the \_\_\_\_\_, \_\_\_\_\_ and \_\_\_\_\_, and also \_\_\_\_\_ God's \_\_\_\_\_.

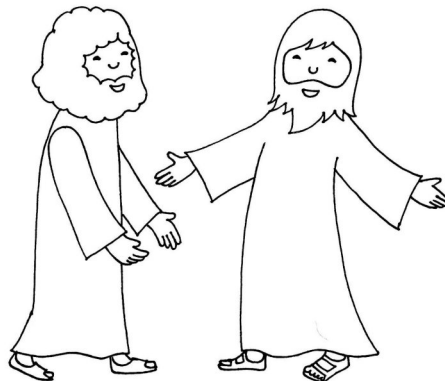
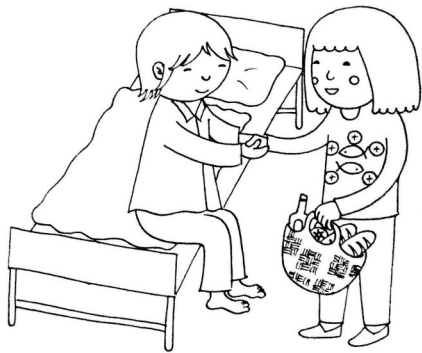

**FELLOWSHIP**

1. God uses the analogy of a body to describe the relationship believers have with one another and with Jesus Christ. But who is the head of the body?

Colossians 1:18 says, "\_\_\_\_\_ is the head of the body."

2. Each believer is given different but equally important responsibilities in this spiritual body, the church. Let's read 1 Corinthians 12:14-27.

a. Who gave the members their various functions? (v. 18)

b. What bad attitudes can lead to disharmony in the body of Christ? (vv. 15-16, 21)

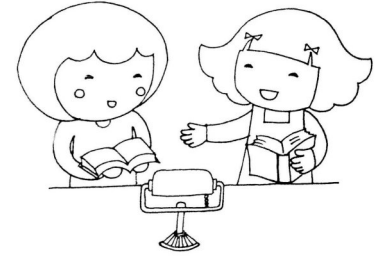

c. Why are there no unnecessary functions (members) in the body? (v. 20-22)

3. "Fellowship" is from the Greek word koinonia, which means, "sharing in common." So what kinds of things can we share, and with whom? Pair up with a friend or two and come up with some things that we can share, and with whom we can share these things. Then, draw what you came up with in the boxes below.

### WE CAN HELP THE CHURCH

Even though we are young, what we do makes a difference! As Paul encouraged Timothy, "Don't let anyone look down on you because you are young, but set an example for the believers in speech, in conduct, in love, in faith, and in purity."

**Instructions:** Read the following scenarios and write down what you would do in that scenario.



**Scenario #1**

Haley went to church on Saturday. After the morning sermon, a church council member announced that there was a family visiting from another state. One of the kids in the family was around the same age as Haley. After the announcement, Haley went to get lunch. In the lunch line, she noticed that the visiting family was right behind her in the line.

**If you were Haley, what would you do next as part of a church that shows love?**

---



---



---



---



**Scenario #2**

After RE class ends, Billy sees some E1 students playing tag around the church. To avoid getting tagged, some of the kids are running pretty quickly. Billy sees one of the E1 students knock down some pencils and books from a table.

**If you were Billy, what would you do next to help the church?**

---



---



---



---

### TESTIMONY: THE BLESSINGS OF FELLOWSHIP

There was a brother who moved to a new area. Moving to a new area was a big challenge. He had to adapt to a new school, new friends, and a whole new environment.

Thank God, in that area there was a strong fellowship. They had a prayer meeting every Wednesday night, when the members would come together to share about their week and their prayer requests, then pray for thirty minutes. From these prayers, he felt that there was something in this fellowship that he couldn't find in any other group or club—a family in Christ.



During the year, he faced a difficult trial. He felt pressure to conform to what his school friends were doing. There were other friends who would listen to his concerns, but he didn't feel like they had the heart to sympathize. However, when he brought this up to the fellowship, he finally felt that there were people who sincerely cared about his situation. They offered him words of encouragement from their own experiences, which he cherished. But it was their willingness to pray for him that really touched his heart.

How many people are there who honestly intercede on your behalf to the heavenly Father when you go to them with an issue? All the words and ideas in the world can only do so much, but truly it is only prayer that can bring about a resolution. Through the prayer and support in this fellowship, he received the strength from God to overcome the trial he was facing. From that point on, he felt the spiritual peace and confidence to stand strong in front of his school friends.

#### Questions to Think About

1. How did the fellowship impact this brother's life?
2. What do you think his life would have been like if he had not joined this fellowship?
3. Do you have a fellowship in your area? Please share what it's like.

## E2 Year 2 Book 2 Lesson 1—My Church and I

# Homework Assignment

Name: \_\_\_\_\_ Parent signature: \_\_\_\_\_ Date: \_\_\_\_\_

**Weekly Bible Reading:** \_\_\_\_\_

**Bible Reading:** Check each box when you complete that day's reading.

**Prayer:** Check each box after you pray to God that day.

	Sun	Mon	Tue	Wed	Thu	Fri	Sat
Read							
Pray							

### What I Learned from the Bible This Week

1. \_\_\_\_\_  
 \_\_\_\_\_  
 \_\_\_\_\_
2. \_\_\_\_\_  
 \_\_\_\_\_  
 \_\_\_\_\_

### Memory Verse

Please write down this week's memory verse. **(Acts 2:42)**

\_\_\_\_\_

**True or False**

1. Jesus' disciples were gathered in Jerusalem when the Holy Spirit descended. \_\_\_\_\_
2. With the help of the Holy Spirit, five thousand people were baptized on the Day of Pentecost. \_\_\_\_\_

**Short Answer**

3. Name three things the early believers did together.
  
  
  
4. What are two ways the Bible describes the church?
  
  
  
5. What does "pastor" mean? Who is the flock?
  
  
  
6. How does the Bible first describe Timothy?
  
  
  
7. Name two duties of our church ministers today.

# LESSON 2

## I CAN HELP MY CHURCH



### OBJECTIVES

1. To understand the extent of God's love, and how to commit ourselves to loving God and our brethren, both in speech and in action
2. To learn to be faithful in attending church and RE classes.
3. To learn how to put our faith into action, first by praying for the church and its workers, and second by bearing the responsibilities of work in the church.

### MEMORY VERSE

"This is My commandment, that you love one another as I have loved you."

(John 15:12)

### PRAYER

1. Thank you God for guiding us through the week so that we can gather together on this Sabbath day.
2. We thank You for our spiritual friends at church with whom we can worship You, and with whom we can grow together, spiritually.
3. We ask You to give us wisdom so that we can understand how to put our faith into action, by helping one another and by spreading Your love.



### Overview

#### 1. How We Can Help Our Church

- God's Love and Loving Our Brethren
- Attending Church and RE Classes
- Putting Our Faith into Action
  - o Pray for our church, its pastors, and its workers
  - o Help carry the workload of responsibility
  - o Live and conduct ourselves in a Christ-like manner

#### 2. Linking to the Ten Basic Beliefs—Salvation is given by the grace of God through faith.

#### 3. Life Application

- Testimony: Helping One Another
- Love in Speech and Action

#### 4. Activity—Good Samaritan Desk



### Background Knowledge for Teachers

#### What "Church" Means for Us Today

A church is made up of its members, not the building itself. "Church" comes from a Greek word that means, "called out assembly." The Jews had been "called out" from the nations to be God's special people. Today, the church is made up of people who believe in Jesus and follow Him obediently. Most importantly, the church comprises people who were bought with the blood of Jesus Christ (Acts 20:28). The Bible uses different imagery to help us understand what Jesus' church is like.

#### *The Church Is One Body*

The Bible describes the church in two ways. First, the church is one body. People who believe in Jesus are linked together, as parts of a body are linked together. Each person has a special job in the body, just like the arms, legs, and other parts of our body. When we view the church as a body, it helps us realize that each of us is important, and that each of us has a different way to serve God and other people.

#### *The Church Is One Family*

The second way the Bible describes Jesus' followers is by saying we're a family. Christians in the New Testament era called each other brothers and sisters. This was because they loved each other as such (1 Tim 5:1-2). The church, then, is made up of people who are family. We will not be alone if we take time to become friends with others in church. Even though we are not blood related, the blood of Jesus Christ has washed us all. We should love and support each other as a spiritual family.

*Pastors*

As part of the body of Christ, each of us has our own role as different “limbs.” One of these roles is that of a pastor who leads the church. One of Jesus' favorite metaphors for spiritual leaders was that of a shepherd—a person who tends God's flock. In fact, the definition of the word “pastor” is “to shepherd.” The flock that the pastor must shepherd refers to the church members. A shepherd must lead, feed, nurture, comfort, and protect the sheep. These are all responsibilities that a pastor—or a minister as we sometimes call them—must shoulder.



## Reaching Out to Your Students

James 2:14-24 speaks of faith being justified by actions. Since your students have been taught the importance of prayer and reading the Bible, this lesson might confuse them; they might wonder why it's not enough that they simply pray and read the Bible, or why, if these are ineffective, they should continue doing either of them at all.

Try to help your students understand that God loves when we pray and read the Bible, as these are methods for us to cultivate our faith and draw nearer to Him. However, we should also strive to love one another to show Him our faith, and also to let others see God's love in us.



## Opener

*5 Minutes*

There was once a righteous man named Martin. Martin was a general in the army, and one night, he was heading off to battle with his fellow soldiers on his way to battle. Martin and his men rode on horses, and because it was in the dead of winter, they each had a heavy red blanket to keep them warm.

While they were on their way, they came across an old beggar dressed in rags and shivering in the freezing cold. One by one, the beggar approached each soldier with his hand outstretched, asking for help, and each of them laughed, and kicked him away and mocked him. Finally, he got to Martin. As the beggar came close, Martin drew his sword. The beggar was so afraid, thinking that Martin was about to kill him, but instead, Martin lifted up his red blanket and sliced it in half. He took the larger half of the blanket and draped it over the beggar's shivering body so that he could have some comfort from the severe cold. Martin rode away on his horse before the beggar even had time to say thank you.

That night, Martin had a dream. In his dream, he saw Jesus surrounded by angels in heaven, and Jesus had half of a red blanket draped over his shoulders. The angels asked Jesus, “Where did you get that cloak, my Lord?” Jesus smiled and answered, “This is the cloak that Martin gave to me today.”

This story teaches us that when you do something good for someone in need, you are not just doing something for them, you are doing something for God. When we show love to other people, we are showing love to God at the same time.

[Ask your students to each try to remember the last time somebody did something nice for them. As a teacher, start by volunteering your own story about the last time somebody did something kind for you when you needed help, and how that made you feel.]

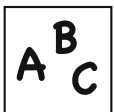

## Vocabulary

**encourage:** to make someone more determined, hopeful, or confident

**flock:** the members of the church; Jesus is our Shepherd





## Bible Discovery & Spiritual Teaching

30-35 Minutes

In the previous lesson, we talked about what a church is. Let's refresh our memories on what we have learned.

### What is the church?

"Church" comes from a Greek word that means, "called out assembly." The Jews had been "called out" from the nations to be God's special people. The church is made up of people who believe in Jesus and follow Him obediently. Most importantly, the church comprises people who were obtained with the blood of Jesus Christ (Acts 20:28). Last week, we learned two pieces of imagery to help us understand what Jesus' church is like. Do you remember what they are, and what they mean? [Allow students to answer if they can; answers are in the two paragraphs below.]

The Bible says that the church is a body. People who believe in Jesus are part of one body, and as such, each individual has their own roles to perform, just like an arm or a leg. This image helps us realize that each of us is an important member with an important role that God has prepared just for us.

The Bible also says we should treat our fellow members like brothers, sisters, mothers, and fathers. Even though we are not blood-related, being washed by Jesus' blood makes us a family, and we ought to treat one another with love.

Last week, we also learned about some of the roles of a pastor. Can you name all of them? [Allow students to answer if they can.]

1. Evangelism
2. Administering the sacraments
3. Teaching and preaching
4. Shepherding God's sheep

### How We Can Help Our Church

This week, since we now know what kind of responsibilities our ministers have, we're going to learn what we can do, and how we can help our church. Before we begin, though, there are six important teachings that we need to understand.

This week, since we now know what kind of responsibilities our ministers have, we're going to learn what we can do, and how we can help our church. Before we begin, though, there are six important teachings that we need to understand.

#### 1. God's Love and Loving Our Brethren

Let's open our Bibles to Luke 10:27 and read it together.

It's easy for someone to tell you to love God and to love your neighbor, but what does this involve? Let's first examine what Biblical love is.

#### FOR TEACHERS

Hand out Bible Discovery Worksheet #1 and work on it as a group.

Love enters into our everyday actions in a variety of ways. Many people give only when they can receive, as illustrated in the saying, "If you do your part, then I'll do mine." This conditional manner of giving is **not** love. God tells us that He loves us. Period. There are no conditions for receiving His love. It is this selfless giving and loving that God wants reflected in our own attitudes and actions.

By clothing ourselves in God's love, we also help to eliminate the elements of conflict and division, which often hinder the unity of the church. Ephesians 4:1-3 says, "I [...] beseech you to walk worthy of the calling with which you were called, with all lowliness and gentleness, with longsuffering, bearing with one another in love, endeavoring to keep the unity of the Spirit in the bond of peace."

#### 2. Attending Church and RE Classes

Attending church and joining together with others in worship encourages the workers and pastors who have prayed and prepared all week to minister to you (Heb 10:24-25).

[Read the following scenario to the students and ask them to listen carefully.] "My parents worked so hard to provide for me throughout their lives. One incident I especially recall is when my mother spent her entire afternoon cooking something special for me for supper. However, preoccupied with something else, I didn't even bother to show up. This hurt my mother, to feel that her labor of love was not appreciated."

We may not realize this, but pastors often feel the same way when their flock doesn't show up. Pastors are always praying and fasting for the needs of the families in the church, such as those who are struggling with their faith. They often work late into the night to prepare teachings that can stir the souls of their sheep, only to find empty seats on Sabbath morning. This can discourage pastors from trying their best.

#### 3. Putting Our Faith into Action

Let's turn to James 2:14-24 and read it together. What does it mean when it says faith without works is dead?

Let's examine these verses more closely. Verses 15-16 asks us a question: If a brother or sister has no food and no clothing, do you think it's okay to just tell them, "It will be okay; I'll pray for you"? Prayer is important, but do you think that's all you should do, especially knowing that you have the ability to give them what they need?

James is telling us that our faith doesn't really matter until we put it into action. In this example, putting faith into action means that we should use the love of God to open our hearts to our brother or sister in need by providing them with what they need. How can we put our faith into action and help our church?

#### **A. Pray for our church, its pastors, and its workers**

*"Therefore I exhort first of all that supplications, prayers, intercessions, and giving of thanks be made for all men, for kings and all who are in authority, that we may lead a quiet and peaceable life in all godliness and reverence." (1 Tim 2:1-2)*

Satan doesn't want the church to advance. Our church workers are always fighting spiritual battles and facing temptations and spiritual conflicts that could interfere with their church work. The devil knows that if he can get a pastor or worker discouraged enough to quit, it can have a domino effect on the rest of the church. You can be a tremendous help by praying fervently for your church and its workers. Paul explains in the Bible that it is the duty of Christians to pray for all who are in authority, especially those in spiritual authority.

#### **B. Help carry the workload of responsibility**

*"Even so you, since you are zealous for spiritual gifts, let it be for the edification of the church that you seek to excel." (1 Cor 14:12)*

Do you remember the story of Moses when Israel fought

Amalek? When Moses held his staff high up, Israel began to win the battle, and when he lowered it, the Amalekites began to win. But Moses' arms became tired from holding the staff up for so long, that Aaron and Hur came to his side and supported his hands, one on each side, so that he could hold the staff until sunset (Ex 17:12). The arms of our church workers often become weary under the weight of so many responsibilities, so they need brothers and sisters, just like Aaron and Hur, to stand beside them to help distribute the load.

Now, you might ask, "But what can I possibly do? I'm just an E2 student!" Well, did you know that God distributes gifts to each within the body of Christ as it pleases Him? God never intended that the whole ministry of the church be carried solely on the pastor or a small group of people. Spiritual gifts are given to all of us so that the church can be edified and built up. But He doesn't just give us these gifts on a silver platter—we need to first discover them, then develop and utilize them under the guidance of our mentors. Are you good at singing? Writing? Maybe you are very detail-oriented or very good at organizing groups of people. Such things are gifts from God, tools for you to use so that you can glorify God and be a help to our church.

#### **C. Live and conduct ourselves in a Christ-like manner**

*"In all things showing yourself to be a pattern of good works; in doctrine showing integrity, reverence, incorruptibility." (Ti 2:7)*

A third thing we can do to put our faith into action and help our church is to set an example for others. A pastor loves to see his flock practicing what he has preached, and other members can learn from you if you set a good example. Truth-seekers, too, can be preached to in this manner without us ever having to say a single word to them!

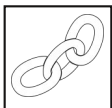

## Linking to the Ten Basic Beliefs

2-5 Minutes

#### **Salvation is given by the grace of God through faith.**

We know that in order to obtain salvation, we must have faith. And in order for our faith to be alive, we must put it into action by loving one another and spreading the love of God to those around us.



## Check for Understanding

5 Minutes

1. **Why isn't it enough to just have faith without doing any works?** Having faith in God is important, but it doesn't mean much if we don't put it into action. By showing our love to others, we are showing our faith to God and also allowing others to see God in us.
2. **How did the Israelites win the battle against the Amalekites?** Moses had to hold up his staff to bring the victory. Anytime he lowered it, the Amalekites would start winning.
3. **What did Aaron and Hur do, and what can we learn from their actions?** When Moses' arms started getting weary from holding up the staff, Aaron and Hur came to his side and helped him hold up his arms. We can learn that we must support our church workers and help them when they become weary from all the responsibilities and duties they hold.
4. **What are some things that God has done in our lives, and how can we repay Him?** Answers may vary. Suggested answer: God has given us so many graces. He gave us sunshine and rain; He protected us; He provided for us through our parents; He gave us all the good things to enjoy. We can repay Him by obeying His words and teachings in the Bible, and shining for Him at school and everywhere.
5. **What are some nice things we can do for other people, and for our brothers and sisters in church?** Follow the examples Jesus set; practice kindness; greet one another; help those who are weak; help those who are sick; clean and wipe the tables; keep our classroom clean; keep the church clean; etc.



## Life Application

10 Minutes

### 1. Testimony: Helping One Another

[Hand out Life Application Worksheet #1. Read the testimony aloud, or ask the students to take turns reading. Then, Read the summaries and ask students to list out different ways they can do the following actions.]

#### How Can I Help Others?

*A. Look out for brothers and sisters in need.*

Think of the people you know at church that don't have many friends or that don't come to church very often, and make friends with them. Sometimes, it's as simple as saying "hi," or inviting them to eat lunch with you. God tells us that every one of His children is important, even the ones that are shy or going through hard times. By looking out for those who are lonely, or the ones that might need a friend, we are reminding them that they are important to God too, and that He loves them!

*B. Follow the example Jesus set.*

Because God gave us Jesus to look up to, we have the perfect example to follow! We can remember all of the things that Jesus did for the people while He was here on earth, and try to do those same things for other people. For example, Jesus spent time with many people and taught many things. He showed lots of love, and when someone needed Him, He would go to them. If we encounter a situation where we're not sure how we should act, we can simply ask ourselves, "What would Jesus do in this situation?"

*C. Practice small acts of kindness.*

From Mary's testimony, we learned that nice things we do don't have to be big or time-consuming. Even the simple, small things we do count! So if you're not used to serving others, or you don't know how to start helping others, just think of the little things you can do. For example, after someone is done eating, you can take their plate to the sink for them. Or, if you are about to get a glass of water, you can ask the people around you if anyone would like one as well. Or if you see some garbage on the ground, you can pick it up and throw it away. Any little thing you do means something to someone, and ultimately, it will help you grow accustomed to showing God's love by living a life filled with small acts of kindness.

**How Can I Share God's Word?***Be kind to everyone you meet.*

Chances are, if you are kind to others outside of church, they will know that you are a Christian. If you practice acts of kindness and look out for the people around you who are lonely or who don't have many friends, people will think to themselves, "wow, this person is so kind and helpful – I wonder how they learned to be that way?" Your own kindness can be the door through which other people learn about God. If we should godly love to people who have never even read the Bible before, wouldn't that be a wonderful way to introduce them to God?

**2. Love in Speech and Action**

[Hand out Life Application Worksheet #2 and go over it with the students. Answers have been provided below.]

**Colossians 4:6** "Let your speech always be with grace, seasoned with salt, that you may know how you ought to answer each one." (Speak kindly at all times so you can help others with your words.)

**With the help of the Spirit, we can speak gracious and loving words. What can the right words do?**

Prov. 12:25: A good word can make a man's heart glad.

Prov. 15:23: A word spoken at the right time is good.

Prov. 16:24: Pleasant words are like honey, sweet to the soul and health to the bones.

Prov. 23:16: When you say the right thing, God will be happy.

Love is not merely a feeling, but an act of will. It can only be known by the actions it produces. What are some practical ways you can personally demonstrate love in action towards the following people? Discuss with each other, and then write down some ideas that you plan to try. [After students have completed this section, invite them to share their answers.]

**Activity****A Good Samaritan Desk***10-15 Minutes*

**Objective:** To help students understand the importance of helping others who are in need.

Do you personally know of anyone who is confined to bed because of a sickness? Have you ever checked with the pastors to see if anyone may be lonely? Here is an easy lap desk you can make to give someone some help and cheer!

**Materials**

- Medium-sized cardboard box (at least 8" X 10" X 15")
- Piece of cardboard matching the width and length of the box (optional)
- Poster paint (alternately: spray paint or spare wall paint)
- Glue
- 2 manila envelopes per desk
- Scissors
- X-Acto knife (optional)
- Pencils

**Instructions**

1. Get a box big enough to fit over your lap.
2. Cut off the lids from the top of the box and save them.
3. Turn the box upside down. The bottom of the box will be the top of the desk, so if it has an opening, glue a piece of cardboard over the entire bottom on the outside. Optionally, you can glue an extra piece of cardboard to the top to reinforce the writing surface.
4. Cut a rectangle out of one of the long sides of the box, making sure to start from the bottom edge. It should be no closer than 2" to the corners or sides. Use the rectangle you cut out to trace and cut out another rectangle on the opposite side. [Teachers: You can choose to use an X-Acto knife, but use caution around students.]



5. Glue the lids of the box to the sides that have not been cut so they stick up 1/2-1" above the "top" of the table. This rim will keep pencils from rolling off.
6. Paint the whole desk.
7. Glue manila envelopes on the sides to hold paper.
8. Give the desk to someone and supply that person with encouraging Bible verses.

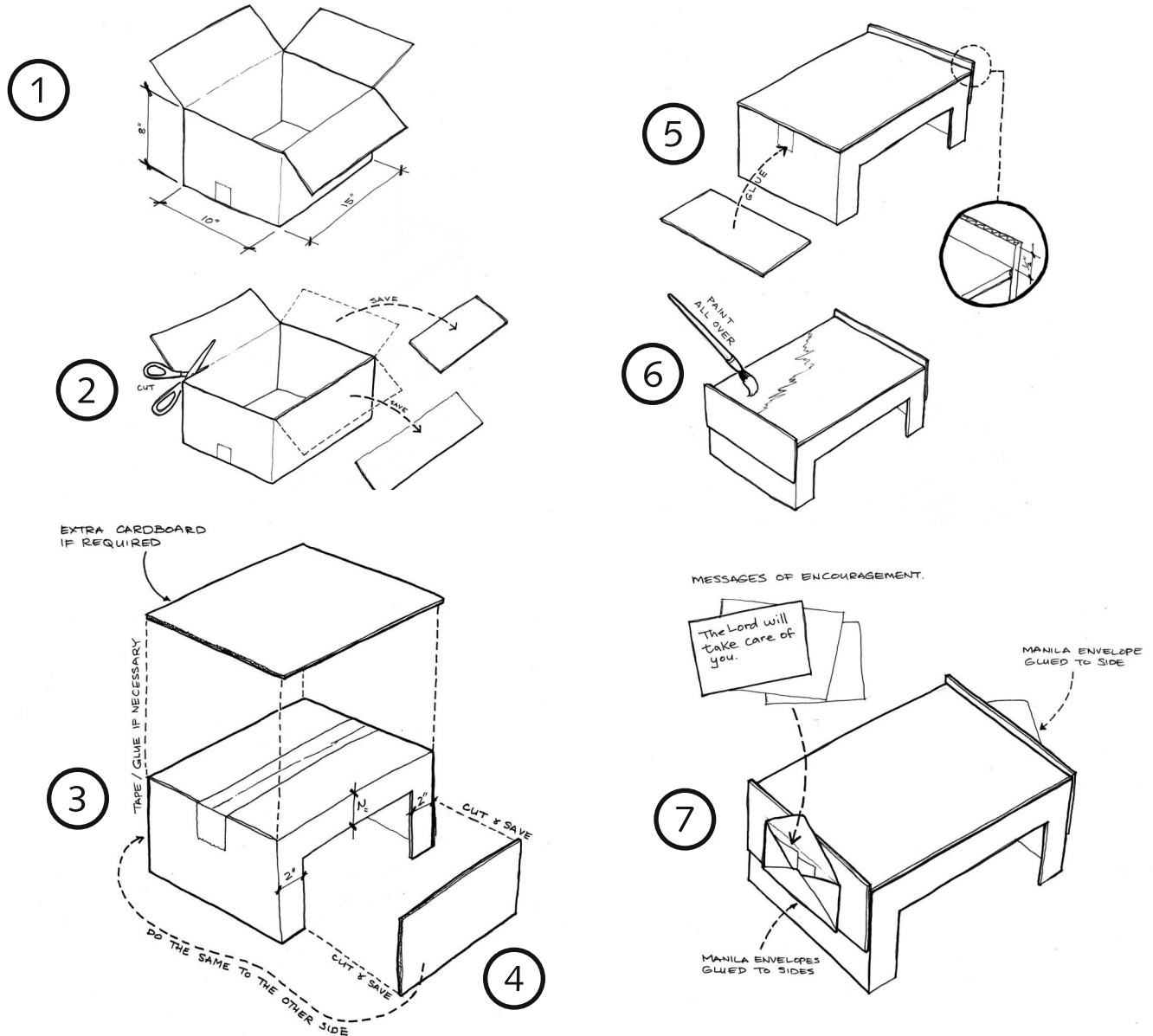

HOMWORK ANSWER KEY

1. "So he answered and said, " 'You shall love the LORD your God with all your heart, with all your soul, with all your strength, and with all your mind,' and 'your neighbor as yourself.'"
2. James is telling us that our faith doesn't really matter until we put it into action. In this example, putting faith into action means that we should use the love of God to open our hearts to our brother or sister in need by providing them with what they need.
3. win, win
4. Aaron and Hur (Ex 17:12)
5. Look out for brothers and sisters in need; follow the example Jesus set; practice small acts of kindness; be kind to everyone I meet; share God's word.
6. C
7. He emphasized showing love so that people know that we are His disciples. Answers may vary.

## I CAN HELP MY CHURCH

Today, people have many different definitions of love. Most of these come from the illustrations of love found in television shows, movies, advertisements, magazines, and perhaps from personal experiences. However, not many people turn to the Scriptures, which also speak to us directly about love. It tells us what love is, and how we may demonstrate it.

### Discussion Questions

1. What is the world's concept of love? Consider movies or books that you have seen or read.
2. What do you think genuine love is?
3. How do the two loves differ? Read the paragraphs below, and then reconsider this question.

When we think about love as defined by the world, we often associate it with physical relationships, desires, or even simply having a strong liking for something.

The Bible, on the other hand, defines love differently. The original language of the New Testament, Greek, uses the word *agape*, which means God's love, or sacrificial love. *Agape* is love that is of and from God, whose very nature is love itself. The apostle John affirms this in 1 John 4:8, where he says that "God is love." God does not merely love us; He is love in and of itself.

Since God is love, everything God does is a result of this. But it is important to remember that God's love is not a sentimental love that we often see or hear portrayed. God loves us because that is His very nature and the expression of His being. God's love is displayed most clearly at the cross. Romans 5:8 says, "But God demonstrates His own love toward us, in that while we were still sinners, Christ died for us." He did not give His life because we did anything to deserve it. This is *agape*.

### Love According to the Bible

1 Corinthians 13:4-8 gives us some of the characteristics of biblical love. Turn to the passage, read it, and then fill in the chart below.

WHAT LOVE IS	WHAT LOVE IS NOT
1. Patient	1. Envious
2. Kind	2. Proud
3. Rejoices in the truth	3. Rude
4. Bears all things	4. Self-serving
5. Believes all things	5. Rejoice in iniquity
6. Hopes all things	6. Provoked
7. Endures all things	7. Evil
8. Never fails	8.

Based on this passage, what are one or two major conclusions you can make about love?

**Next, turn to 1 John 4:8-21 and discuss the following questions.**

1. What important teaching about God did you read in v. 8?  
*God is love.*
2. What has God done to demonstrate His love for us?  
*He sent His only Son, Jesus Christ, to the world. He died for us and our sins so we could live.*
3. What should our response to God's love be? (vv. 11, 19)  
*We should love God and show love to one another.*

**Lastly, turn to John 13:34-35 and discuss the following questions.**

1. What is sure evidence that you are follower of Christ?  
*If you love others as Christ loved you.*
2. Why do you think Jesus placed such emphasis on demonstrating love?  
*Jesus emphasized love because God is love. God loves all of us so much. He sent His only Son to die for our sins so that we could spend eternal life with Him in the kingdom of heaven. Not only that, He showers us with so many blessings each day. He desires for us to show others the same kind of love that He has shown us.*

### I CAN HELP MY CHURCH

Today, people have many different definitions of love. Most of these come from the illustrations of love found in television shows, movies, advertisements, magazines, and perhaps from personal experiences. However, not many people turn to the Scriptures, which also speak to us directly about love. It tells us what love is, and how we may demonstrate it.

**Discussion Questions**

1. What is the world's concept of love? Consider movies or books that you have seen or read.
2. What do you think genuine love is?
3. How do the two loves differ? Read the paragraphs below, and then reconsider this question.

When we think about love as defined by the world, we often associate it with physical relationships, desires, or even simply having a strong liking for something.

The Bible, on the other hand, defines love differently. The original language of the New Testament, Greek, uses the word agape, which means God's love, or sacrificial love. Agape is love that is of and from God, whose very nature is love itself. The apostle John affirms this in 1 John 4:8, where he says that "God is love." God does not merely love us; He is love in and of itself.

Since God is love, everything God does is a result of this. But it is important to remember that God's love is not a sentimental love that we often see or hear portrayed. God loves us because that is His very nature and the expression of His being. God's love is displayed most clearly at the cross. Romans 5:8 says, "But God demonstrates His own love toward us, in that while we were still sinners, Christ died for us." He did not give His life because we did anything to deserve it. This is agape.

**Love According to the Bible**

1 Corinthians 13:4-8 gives us some of the characteristics of biblical love. Turn to the passage, read it, and then fill in the chart below.

WHAT LOVE IS

WHAT LOVE IS NOT

1.	1.
2.	2.
3.	3.
4.	4.
5.	5.
6.	6.
7.	7.
8.	8.

Based on this passage, what are one or two major conclusions you can make about love?



Next, turn to 1 John 4:8-21 and discuss the following questions.

1. What important teaching about God did you read in v. 8?
2. What has God done to demonstrate His love for us?
3. What should our response to God's love be? (vv. 11, 19)

Lastly, turn to John 13:34-35 and discuss the following questions.

1. What is sure evidence that you are follower of Christ?
2. Why do you think Jesus placed such emphasis on demonstrating love?

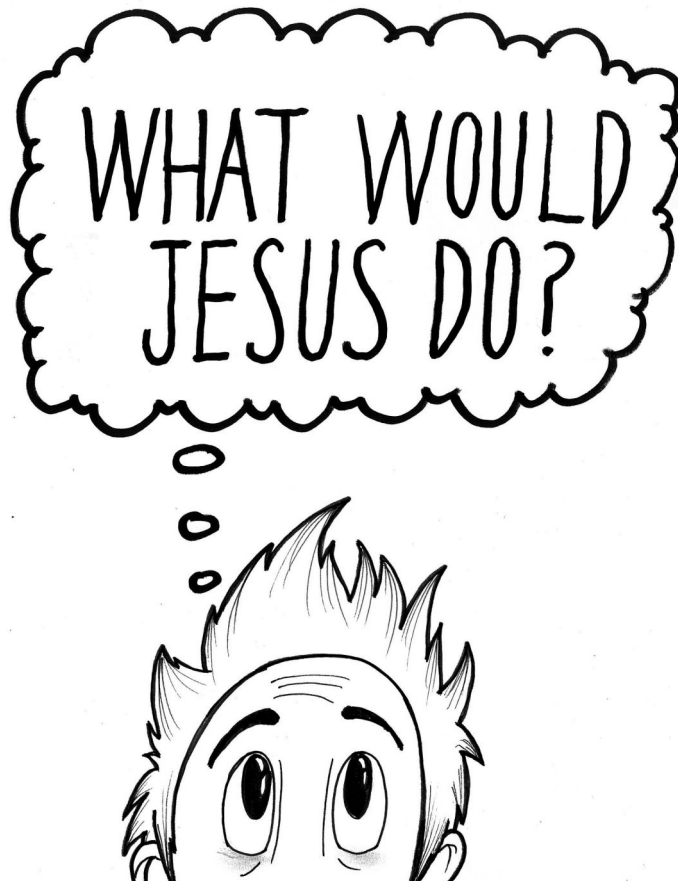

### TESTIMONY: HELPING ONE ANOTHER

There was once a sister, whom we'll call Mary in this story. Mary had not attended church for a very long time. She had been going through some difficult things in life, and had become very distant from God, feeling as though He was very far away from her. Mary also felt very lonely—she felt that she didn't have many friends, and that no one seemed to care about her. Her heart was miserable, and she felt lonesome.

One day, a couple of church members came to visit Mary to talk with her. They were worried about her because she wasn't attending church anymore, so they came to her house to chat and make sure she was okay. While they were sitting and talking, one of the visiting members got up and started bustling about in the kitchen.



She came out a few minutes later with a cup of tea and handed it to Mary. As soon as she handed it over, Mary began to cry. She had spent so long feeling sad and lonely that she was touched by the simple act of this church member taking the time to make her a cup of tea. Even though it was such a small gesture, for someone like Mary whose heart was in pain, it meant the whole world that someone cared enough to do something nice for her.

After the visit, Mary began to attend church again. God opened her heart to experience the love of the brothers and sisters around her, and because of this, she was able to see God's love. She was finally able to feel joy.

From this testimony, we can see that doing something nice for someone doesn't have to be something big, such as buying an expensive gift or walking a thousand miles! If we have the love of God in our hearts, even the smallest things that we do have a greater impact than we could ever imagine! Think of the little boy who came to Jesus with five loaves of bread and two fish—that was just his tiny little lunch, but Jesus was able to turn that tiny little lunch into a feast that fed five thousand people!! This just goes to show that God has the power to turn tiny acts of kindness into giant acts that can touch many hearts, as long as we act with faith!

#### How Can I Help Others?

List different ways you can do the following actions.

- A . Look out for brothers and sisters in need.
  
- B. Follow the example Jesus set.
  
- C. Practice small acts of kindness.

### How Can I Share God's Word?

*Be kind to everyone you meet.*

**LOVE IN SPEECH AND ACTION**

Read Colossians 4:6 and rewrite the verse in your own words.

---



---

With the help of the Spirit, we can speak gracious and loving words. What can the right words do?

Prov. 12:25 \_\_\_\_\_

Prov. 15:23 \_\_\_\_\_

Prov. 16:24 \_\_\_\_\_

Prov. 23:16 \_\_\_\_\_

Love is not merely a feeling, but an act of will. It can only be known by the actions it produces. What are some practical ways you can personally demonstrate love in action towards the following people? Discuss with each other, and then write down some ideas that you plan to try.

1. My parents
2. My siblings
3. My friends at school
4. Church members
5. Others (neighbors, relatives, etc.)



I'm going to try to demonstrate my godly love to \_\_\_\_\_ by...

I'm going to try to demonstrate my godly love to \_\_\_\_\_ by...

I'm going to try to demonstrate my godly love to \_\_\_\_\_ by...

## E2 Year 2 Book 2 Lesson 2—I Can Help My Church

# Homework Assignment

Name: \_\_\_\_\_ Parent signature: \_\_\_\_\_ Date: \_\_\_\_\_

Weekly Bible Reading: \_\_\_\_\_

**Bible Reading:** Check each box when you complete that day's reading.

**Prayer:** Check each box after you pray to God that day.

	Sun	Mon	Tue	Wed	Thu	Fri	Sat
Read							
Pray							

### What I Learned from the Bible This Week

1. \_\_\_\_\_  
\_\_\_\_\_
2. \_\_\_\_\_  
\_\_\_\_\_

### Memory Verse

Please write down this week's memory verse. **(John 15:12)**

\_\_\_\_\_

1. Look up Luke 10:27 and write down the verse.
  
2. In the Book of James, what does it mean when it says faith without works is dead?
  
3. Fill In the Blank: When Moses held his staff high up, Israel began to \_\_\_\_\_ the battle, and when he lowered it, the Amalekites began to \_\_\_\_\_.
  
4. When Moses' arms became tired from holding the staff up, who came to his side to support his hands?
  
5. List at least 4 ways you can help your church that you've learned from class.
  
6. \_\_\_\_\_ : God did not give His life because we did anything to deserve it. What kind of love is this?
  - a. Human love
  - b. Parental love
  - c. God's unfailing love: agape
  
7. Why do you think Jesus placed such emphasis on demonstrating love? Write down one thing that you can do this week to help:
  - a. Your parents \_\_\_\_\_
  - b. Your friends \_\_\_\_\_

# LESSON 3

## SEEK TO DO GOD'S WILL, AND BE THANKFUL AT ALL TIMES

### OBJECTIVES

1. To understand that we should seek after God's will and submit to His will.
2. To know that giving thanks at all times is God's will.
3. To remember that God answers prayers according to His will.

### MEMORY VERSE

"Rejoice always; pray without ceasing; in everything give thanks, for this is the will of God in Christ Jesus for you."

(1 Thessalonians 5:16-18)

### PRAYER

1. Thank You, God, for allowing us to be here on this wonderful Sabbath day to worship You.
2. Today, we are going to learn about the purposes behind Your will and the attitude we should have when praying for Your will.
3. Lord, please place in our hearts a desire to follow Your will for us and to be thankful for what You have given us at all times.
4. May Your presence fill our classroom today so that we may experience the power of Your knowledge and wisdom.



### Overview

1. **A Healed Leper Gives Thanks to God (Lk 17:11-19)**
2. **Apostle Paul Accepts the Will of God (2 Cor 12:7-10)**
3. **Linking to the Ten Basic Beliefs**—The Holy Bible
4. **Life Application**
  - Scenario: Putting God's Will First
  - Submit to God's Will
5. **Activity**—Thank You, Lord!



### Background Knowledge for Teachers

#### A Healed Leper Gives Thanks to God (Lk 17:11-19)

When Jesus and His disciples were on their way to Jerusalem, shortly before the Crucifixion, they passed along the border of Galilee and Samaria where they met ten lepers who called on Jesus for mercy. Since the time of Moses, the Hebrews observed special laws concerning leprosy (Lev 13). When a man was declared to have leprosy, he was required to wear torn clothing, leave his head uncovered, and live outside the town. When anyone approached, he had to cover his upper lip and call out, "Unclean! Unclean!" Leprosy was believed to be a contagious disease and there was no cure at that time.

Priests were responsible for recognizing the symptoms of leprosy, which begins with whitish sores. Fingers with the sores often wasted away, becoming shorter and shorter, and then shriveling away into the deteriorating hand. The nose sometimes receded into the face. Toes might fall off. As the disease advanced and the flesh began to decay, a terrible smell would be added to the misery. Sometimes, the disease could burn itself out and stop. If a person believed that this had happened to him, he could go to the priest and the priest would decide whether the person could return to a normal life. This is the reason Jesus told the ten lepers to go and show themselves to the priest after healing them.

#### Apostle Paul Accepts the Will of God (2 Cor 12:7-10)

On more than one occasion, Apostle Paul mentioned his physical affliction in his letters to different churches. This affliction, which he referred to as a "physical infirmity" (Gal 4:13), may have been a problem with his eyes because he wrote to a Galatian Christian that "if possible, you would have plucked out your own eyes and given them to me" (Gal 4:15). Whatever this affliction was, it was evidently painful and chronic. Paul prayed for release and asked God to remove his sickness. However, God's will was not to heal Paul but to give him strength to endure his pain.

Paul said that a thorn was put into his flesh and the devil's messenger was sent to plague him in order to keep him from being proud because of his wonderful experience of getting a glimpse of Paradise (2 Cor 12:1-6). He also understood that God's will was for him to realize that His love is enough for him and that His power was doing its best work. Therefore, in response to God's answer, Paul delighted himself in following God's will and gloried in his affliction. He said, "If I must boast, I will boast in the things which concern my infirmity. [...] Therefore I take pleasure in infirmities, in reproaches, in needs, in persecutions, in distresses, for Christ's sake. For when I am weak, then I am strong" (2 Cor 11:30; 12:10). These words of Paul's do not reflect the natural reaction to pain. The capacity to think this way can only come from God. Paul was willing to accept God's will, whatever it might be, without any reservation. This is a great example of how Christians should fully yield to the will of God.



## Reaching Out to Your Students

Your students, being raised in Christian homes, probably have already learned to say "thank you" to God. However, to many of them thanking God is merely a duty or words that do not have real and personal meanings. Explain to your students that we need to thank God because everything we have has been given by Him—the air that we breathe, the food that we eat, the people who love us, etc. Help them realize that we should not take these things for granted, as God has the prerogative to take anything away from us. So, we should appreciate what He has given us. Encourage your students to thank God on a regular basis, maybe every night before they go to bed, not just for the same thing every time, but for God's every blessing we continue to receive. This will help them become closer to God as they learn to appreciate His wonderful grace and mercy.

Upon having a good understanding of how much God loves and blesses us, students can begin to remember what it means to trust in God's goodness when they experience frustrations. Today's lesson not only teaches students to be thankful for blessings but also for God's purposes for us, which may at times be different than what we want. Teach students to pray for God's will and to never be discouraged when God is slow to answer their prayers. God makes everything beautiful in His time, and we need to hold on to our faith in His will for us. Share testimonies with your students, and help them understand how God's will is always the best.



## Opener

*5 Minutes*

[Share some of the information on leprosy provided in the Background Knowledge for Teachers section. To make the information on leprosy even more vivid for your students, bring a piece of cotton soaked in chlorine bleach or ammonia. Seal the cotton tightly in a plastic bag until after you have presented the information on leprosy. Then, release a little of the smell of ammonia or bleach from the plastic bag, and let the children comment on the strong odor.]

Imagine, if someone who smells like this walks into this classroom right now, would you want him to stay around? People with leprosy often smelled bad, and other people were afraid they might catch the disease. In biblical times, nobody even wanted to have anything to do with lepers. Today, we are going to find out what happened when Jesus met some lepers.

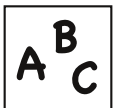

## Vocabulary

**Leprosy** is a terrible disease caused by bacteria. It usually begins with sores that eventually spread all over a leper's body. Doctors in the past could not cure leprosy. People with leprosy were not allowed to live in town; they had to stay outside the city. They could not work at a job or live with their families. When people came near, a leper had to call out, "Unclean! Unclean!" to warn them.





## Bible Discovery & Spiritual Teaching

30-35 Minutes

Imagine this scenario: Ten unhappy men huddled by the side of a road near a village. They were not allowed into the village with others, not even their families. How did they end up being isolated? Did they do something wrong? No, these men didn't do anything wrong. They were isolated because they caught a disease thought to be extremely contagious, called leprosy, which no medicine could cure at that time. On Bible Discovery Worksheet #1, you will find the diary of one of these lepers who wrote about how he ended up being outside of the village.

### FOR TEACHERS

Hand out Bible Discovery Worksheet #1. Keep a copy of the worksheet to reference. Guide students to complete Entry A, B, C, and D. Answers have been provided below.

#### Answers

Entry A: leprous, white, deeper, seven

Entry B: seven

Entry C: white, deeper, unclean

Entry D: Jewish, Samaritan

**Ask the following questions and allow time for student responses after going through the diary entries:** What are your thoughts now that you've read about the feelings of this leper? Do you sympathize with lepers? Are there situations in your life when you feel you are somehow a little like them, though not so in the physical sense?

Poor man! He didn't do anything wrong to deserve such a hopeless and distressing life. Sometimes, but not very often, a person with leprosy would get well and the priest would give permission to the leper to live at home in his own village again. This Samaritan leper's family and friends were probably desperately hoping that he would be one of the few lucky ones to get well. But other than hoping, no one was able to actually do anything to help him. We as human beings are limited.

One day, the sound of a crowd made these ten lepers look up. They saw Jesus walking with some of His followers. The lepers, who had probably previously heard about Jesus and His healing power, lifted up their voices immediately to stop Jesus. What do you think they wanted from Jesus? [Let students answer.] They wanted Jesus to heal their leprosy! We don't know how long these lepers had been isolated nor do we know how bad their leprosy was, but we do know that they were in a hopeless situation and that Jesus brought them hope! Now you might think, would Jesus help these abandoned people that no one was even willing to approach? What do you think? [Let students answer.] Jesus did not care that these ten men smelled foul, wore torn clothing, or were penniless and horribly infected from head to toe. Instead, He had mercy

on them. Jesus said to the ten lepers, "Go, show yourselves to the priests."

Did Jesus mean they were well? The lepers probably wondered. They looked at their hands and feet; there was no change. Sores and scabs still covered their skin. They could go to the priests only if they believed that they were healed from leprosy. Jesus, as in other times, required faith from the sick persons before performing miracles of healing. So, these lepers started down the road toward the village to see the priests. Then it happened—they felt different! They saw that their skin was smooth and clean. They felt strong! They began to run and jump and laugh. They were healed. Jesus had healed them!

These lepers started running down the road to find the priest. They could hardly wait. Suddenly, one of the men in the group stopped and returned to Jesus. He was the Samaritan leper! He arrived in front of Jesus and praised God in a loud voice, "Glory to God! Glory to God for His goodness to me!" Then, he threw himself at Jesus' feet and said, "Thank You, Lord, for healing me." This leper came back to thank Jesus for His healing.

Then Jesus spoke, "There were ten men healed. Where are the other nine? Why did only one come back to say thank you?" To the thankful Samaritan, Jesus answered kindly, "Get up and go. Your faith has made you well." This Samaritan was the only person who turned back to thank Jesus. His faith was confirmed, and he likely continued to pursue after Jesus. On the contrary, the other nine only focused on going to the priests. They quickly forgot about Jesus who made them well—faith meant nothing to them. They lost their only chance to thank Jesus personally and left Jesus disappointed.

How would you feel if a person you generously helped never said thank you to you? [Let students share.] This is probably how Jesus felt at that time. Today, God gives us many blessings—guidance, protection, providence, etc. Today, do we walk away without thanking Him, as the nine lepers did? Do we take God's blessings for granted and leave Him disappointed from time to time?

Before we move on to our next story, let's finish the last diary entry (Entry E) of the Samaritan leper. We should follow his example and give thanks to God for His every blessing.

### FOR TEACHERS

Entry E: leprosy, Jesus, nine, priests, thank, thank you, Jesus

It is so true that when other people see God's work through us, they may come to believe in Him, as we have become evidence to them that God is all-powerful and real. However, this is not the only way we can bear witness to God. The Bible tells us that God is always at work fulfilling His plans for us. He knows what is best for us, and He will at times allow us to suffer, never for more than we can handle, in order to give us the best and keep us humble. In times of suffering, God wants us to believe in His will and remain thankful at all times. He gives us trials and tribulations so that we can exercise our faith in Him and glorify His name when others witness our joy and peace, even in times of troubles.

A good example of joy in tribulation can be found in the story of Apostle Paul. Apostle Paul suffered from a chronic affliction. We don't know what his ailment was, but we do know that it made Paul uncomfortable day after day. He wanted his problem to go away. He thought it kept him from doing his best work for Jesus.

One day, Paul prayed about it. He said, "Lord, this thing really bothers me. I think I could do a much better job for You if You would take it away." Paul waited, but his problem did not go away. He decided he should go on praying about it, so he prayed again, "God please take this hurt away. It bothers me." It still did not go away, so Paul prayed a third time. God still did not do what Paul asked. Instead, God answered, "Paul, the strength that I give you is enough for anything you will need to do. Trust Me. People will see that your problem doesn't stop you from doing My work."

Now Paul understood, "I can see how God's plan is better. If people see God's strength working in me, they will believe God can work in them, too. They will see how powerful God really is!" So Paul went on serving God. He still had this trouble, but it didn't seem like an impossible problem anymore. In fact, Paul started thanking God for it. People who heard him preach or who read his letters saw God's strength in Paul.

#### FOR TEACHERS

After telling the story of Paul, read 2 Corinthians 12:7-10 with your students. Explain to your students that Paul realized that God's will was for him to glorify His name through his suffering. When we are weak, God is strong and will give us the strength to endure all our sufferings. His strength manifests when we are weak.

God always answers our prayers. When it seems that God doesn't hear our prayers, just as when Paul was waiting for God's answer to his prayer, it is because He is answering in a different way! We know that God wants us to learn to submit to His will. Therefore, sometimes God says "no" to our prayers when we fail to trust His plan for us. Most

often, when we offer prayers that God delights to hear, His answer to our prayers is "yes." However, submitting to God does not only require us to seek after His will, but also to wait patiently for His will to be done. So, many times God's answer will be "wait" instead of an immediate "yes." Does that make sense? Let's analyze a few examples on Bible Discovery Worksheet #2.

Pretend that you are saying the prayers below. Which answer would you expect God to give each of your prayers—"Yes," "No," or "Wait"?

#### FOR TEACHERS

Discuss each prayer with your students and ask them to give their answers before explaining the correct answers to them. Answers have been provided below.

- **Help me obey my parents.**  
Yes. This is what every child should do; God delights in seeing obedient children.
- **Make that mean Patrick fall off his bike and get hurt.**  
No. God wants us to love everyone, including our enemies. Only God can judge and we should not ask God to punish others.)
- **Let me be a teacher in church.**  
*Wait.* It is good to desire to serve God in church, and we can always pray for God to give us wisdom to serve Him. However, we are not yet at the age to teach, and therefore we should wait patiently while praying for God's wisdom to prepare us for when the time is right.
- **Help me invite my friends to church.**  
Yes. God wants us to preach and He will delight in seeing more people come to learn about Him. Every day is a chance to preach, and we can always pray for God to give us the courage to invite our friends to church.
- **Don't let my mom find out that I told a lie.**  
No. God does not want us to lie, and He will not help us cover or hide a lie. God sometimes allows us to learn a lesson so that we do not make the same mistake again.)

Today, we learned about how a healed leper praised God for deliverance from a terrible problem. We also learned, from Apostle Paul's story, how others may praise God when they see a Christian fully yielding to God's will. Paul understood the reason for his problem, and he could see that God's plan was the best. But sometimes, difficult or unpleasant things happen to us, and we can't understand the reason. What can we do then? [Let students share.] The better we get to know God, the more we can trust Him. His plans for us are good; we can depend on Him to take care of us the best way possible, even when we don't understand. As long as we seek to do God's will and strive to be thankful at all times, we can rest assured under any circumstances, knowing that we are in God's good hands.





## Linking to the Ten Basic Beliefs

2-5 Minutes

### The Holy Bible

True Jesus Church believes that the Holy Bible is the word of God, written by inspiration of His Spirit, and that all Scripture always stands true. Therefore, in order to understand the will of God, we can always look into the Scripture for reference. God's will never contradicts His own words. The Holy Bible lays the basis for God's will, and therefore we should always seek to follow the Bible in our pursuit of God's will.



## Check for Understanding

5 Minutes

- 1. Why were the ten lepers not allowed in the village?** Leprosy is believed to be contagious, and there was no cure for it at that time. All lepers were to be isolated once diagnosed with leprosy by the priests. In this case, the ten lepers were sent outside of the village.
- 2. How was Jesus' reaction to the lepers different than those of other people?** No one wanted to get close to the lepers because they were afraid to catch the same disease. However, when Jesus saw the lepers and heard them calling for Him, He had compassion on them and healed their leprosy.
- 3. Who was the leper who turned back to say thank you?** It was the Samaritan leper.
- 4. When Paul was suffering from his affliction, what did he do?** He prayed to God for his pain to go away.
- 5. What was God's answer to Paul's prayers?** God gave Paul the strength to endure his pain instead of releasing him from it.



## Life Application

10 Minutes

### 1. Scenario: Putting God's Will First

[Hand out Life Application Worksheet #1. Read the scenarios with your students and have them discuss the questions that follow. If preferred, separate them into groups and have one person from each group report their answers to the whole class after the discussion. Facilitate each group's discussion as needed.]

### Discussion Questions

#### 1. Why did Stephanie get so angry with everybody? What do you think she was thinking about?

Despite diligent practice and prayers, Stephanie wasn't confident about her performance because she doubted if God would help her, having missed two Sabbaths in order to practice. Observing the Sabbath is God's will, but Stephanie placed her own will, which is to shine at her performance, over the will of God. Stephanie probably knew that and got angry with everybody because she was not confident.

#### 2. Stephanie prayed all week for God to bless her, but in the end, it seemed that He didn't bless her. Why do you think things happened like they did?

God answers our every prayer, but only according to His will. God allowed things to happen like they did because He wanted to teach Stephanie the importance of observing Sabbath. God's blessing and answer to Stephanie's prayer was not a smooth performance, but rather a lesson to learn about following God's will. Stephanie will know better next time that while God is always willing to bless and guide us, we cannot and should not try to alter God's will, such as His desire for us to observe the Sabbath.

#### 3. Do you ever feel like God isn't listening to your prayers? Share an experience. How can we always be thankful to God in all situations?

Let students answer.

## 2. Submit to God's Will

Christians often wonder what God wants them to do concerning their desires and plans. It seems as though God's will is hidden in a buried treasure chest, and we have only small portions of the map to find its location. But is this true? In the Scriptures, we have all the guidance we need in order to live for Jesus Christ. God wants us to follow Him so that He can lead us step by step.

[Hand out Life Application Worksheet #2. For each box, read the reference verse as well as the short scenario with your students. Then, guide them to fill in the blanks in the explanations that follow. The explanations serve to provide a better understanding of the given verses, but do elaborate if necessary. Answers have been provided below.]

**Reference Verse:** *"Rejoice always; pray without ceasing; in everything give thanks, for this is the will of God in Christ Jesus for you."* (1 Thessalonians 5:16-18)

**Answers:** prayers, joyful, thanks

\*This is today's memory verse.

**Reference Verse:** *"Therefore do not be unwise, but understand what the will of the Lord is."* (Ephesians 5:17)

**Answers:** unwise, wisdom

**Reference Verse:** *"And do not be conformed to this world, but be transformed by the renewing of your mind, that you may prove what is that good and acceptable and perfect will of God."* (Romans 12:2)

**Answers:** world, good, acceptable, will

**Reference Verse:** *"Trust in the LORD with all your heart, and lean not on your own understanding; in all your ways acknowledge Him, and He shall direct your paths."* (Proverbs 3:5-6)

**Answers:** trust, heart, direct, acknowledge, understanding

Today, we learned about how we should always seek to do God's will instead of our own. However, this doesn't mean that we cannot pray about things that we want or that God never blesses us with what we desire. The right way to seek after God's will is to put His will above our own will. We need to acknowledge His wisdom and knowledge and place them above what we think is best for ourselves. That said, instead of just telling God what we want, we should always pray for His will to be done. The Bible says, "For I know the thoughts that I think toward you, says the LORD, thoughts of peace and not of evil, to give you a future and a hope" (Jer 29:11). Let's always remember that God has a beautiful plan for us and that we should never be afraid to let go of our own will and pursue after God's will for us. We must learn to rely on God and trust Him fully.

After this lesson, how would you change the way you pray? Think for a minute and write it down at the bottom of your worksheet. [The purpose of this question is to let students summarize the teachings of this lesson.]

### HOMEWORK ANSWER KEY

1. banquet
2. excuses
3. field
4. oxen
5. wife
6. The poor, the crippled, the blind, and the lame
7. The heavenly kingdom
8. God
9. By attending Sabbath service and preparing ourselves by praying for the fullness of the Holy Spirit
10. By making up excuses to avoid God



## Activity

### Thank You, Lord!

10-15 Minutes

**Objective:** To give students an opportunity to hand out invitations for Sabbath service to their friends.

#### Materials

- Hymn book or copies of the hymn, "Thank You, Lord"

#### Instructions

1. Hand out copies of the hymn, or ask students to turn to "Thank You, Lord" in the hymn book.
2. Teach the students how to sing the hymn.
3. Explain the activity to the students.

Today, we're going to do a little lyric-writing project. First, make a list of things for which you want to thank. This shouldn't be difficult! Second, using this list, try to fill in the blanks on your Activity Worksheet. Keep in mind the melody of this hymn, as it will help you decide if your lyrics will go smoothly.

I thank the Lord for \_\_\_\_\_,  
for \_\_\_\_\_ and \_\_\_\_\_.  
My heart is filled with joy and praise,  
Because He guides my way.

Thank you, Lord, for \_\_\_\_\_;  
Thank you, Lord, for \_\_\_\_\_;  
Thank you, Lord, for \_\_\_\_\_;  
Thy will is always the best for me.

4. Assist each student as needed. After they have finished writing their lyrics, ask each student to share what they wrote. If time permits, pick a few students' work and have the whole class sing their versions of the hymn together. Below is an example. (Note: The melody has been embellished to match with the lyrics.)

1 I thank the Lord for True Je - sus Church, for friends and fa - mi - ly. My

5 heart is filled with joy and peace, be - cause He guides my way.

9 Thank you, Lord, for beau - ti - ful home; Thank you, Lord, for school and tea - chers;

13 Thank you, Lord, for food and good health; Thy will is al - ways the best for me.

## MY DAYS AS A LEPER

### ENTRY A

Today, I was brought to the priest because of a bright spot on my skin. People thought that it could be a \_\_\_\_\_ sore (Lev 13:2). It is \_\_\_\_\_ on the skin and does not appear to be \_\_\_\_\_ than my skin, and its hair is not white (13:4). To be safe, the priest is isolating me for \_\_\_\_\_ days (13:4). He said that he would check on me again after seven days and then decide if I am unclean. I am so worried! Leprosy is a scary disease; it's painful and disfiguring. It gets worse and worse as the sores spread all over the body until the person dies. I don't want to be a leper!



### Entry B

Today is the seventh day since I got isolated and the priest came to examine me. Since the bright spot has not gotten any better, he decided to keep me isolated for another \_\_\_\_\_ days (13:5). I am starting to have a bad feeling about this... If the spot is just a scab, it should have healed by now. I really miss my family, and I want to go home!

### Entry C

Two days have passed, and I feel hopeless. The hair on my bright spot has turned \_\_\_\_\_, and the sore appears to be \_\_\_\_\_ than my skin (13:3). It also has spread to other parts of my skin. I know already that this is leprosy. In five more days, the priest will come and pronounce me \_\_\_\_\_ (13:3) and keep me isolated for as long as my leprosy lasts. What should I do? I can only wait to die—to die in pain and loneliness.



### Entry D

It's been a month since I was first isolated. There are nine other men here who also have leprosy. Even though they are all \_\_\_\_\_ and I am the only \_\_\_\_\_, they don't seem to care. The loneliness and despair of being lepers binds us all together in spite of prejudices. Anyhow, I really miss my family. I am so afraid that I will never see them again, not to mention I want to hug my wife and children so much. Still, even if I could see them, I wouldn't be able to stand close to them because leprosy is extremely contagious. I am afraid my children won't recognize me anymore because of these sores that have spread all over my body. Leprosy is taking away everything from me—my family, my health, my happiness, my future, and my life! There is no hope in my life anymore.



### Entry E

I am home with my family right now as I am writing this diary entry... I have been healed from \_\_\_\_\_! I'll never forget this day. God is so good to me; He gave me the opportunity to meet \_\_\_\_\_ who healed me, as well as the other \_\_\_\_\_ lepers. At first, we weren't exactly sure why He wanted us to go to the \_\_\_\_\_, but as we began to walk towards the village, we began to feel the difference on our skin. I then knew that He had healed us! I ran back to \_\_\_\_\_ Jesus and fell on His feet to say \_\_\_\_\_. Words could not express how grateful I was, and I wanted to thank Him personally (Lk 17:11-19). If God didn't give me the chance to meet \_\_\_\_\_; if He wasn't so merciful and kind; if He didn't stop and help me... I would be waiting to die without any hope! I'm so glad to be with my family right now, and I won't take God's healing for granted. I will be kind to others just as He was to me. May all the glory be unto Jesus' name!



**SEEK TO DO GOD'S WILL**

Pretend that you are saying the prayers below. Which answer would you expect God to give each of your prayers—"Yes," "No," or "Wait"? Circle which answer you think God would give, and explain why.

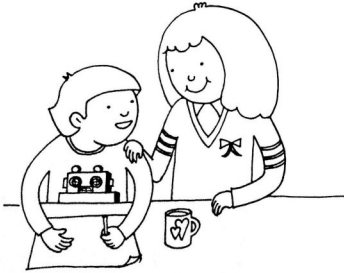

**a. Help me obey my parents.**

God's answer:    Yes    No    Wait

Why would God answer in this way? \_\_\_\_\_

\_\_\_\_\_

**b. Make that mean Patrick fall off his bike and get hurt.**

God's answer:    Yes    No    Wait

Why would God answer in this way? \_\_\_\_\_

\_\_\_\_\_

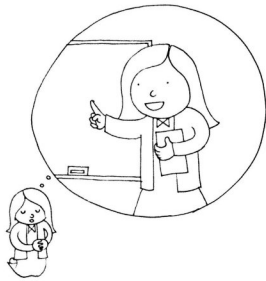
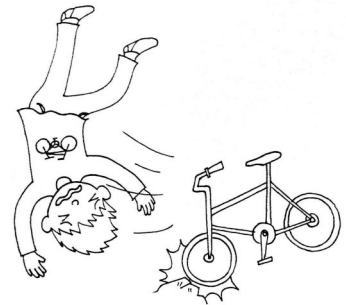

**c. Let me be a teacher in church.**

God's answer:    Yes    No    Wait

Why would God answer in this way? \_\_\_\_\_

\_\_\_\_\_

**d. Help me invite my friends to church.**

God's answer:    Yes    No    Wait

Why would God answer in this way? \_\_\_\_\_

\_\_\_\_\_

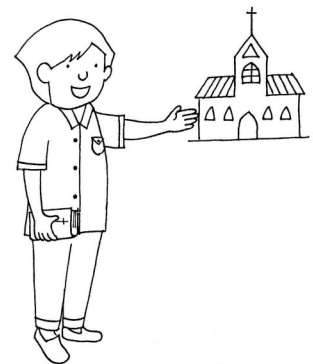

**e. Don't let my mom find out that I told a lie.**

God's answer:    Yes    No    Wait

Why would God answer in this way? \_\_\_\_\_

\_\_\_\_\_



### SCENARIO: PUTTING GOD'S WILL FIRST

Stephanie was especially happy to go to school one day. This was going to be her day to shine. She was supposed to play the flute in front of the whole school. "Wow!" She thought blissfully. "I still can't believe that Mr. Pollack wanted me to do a solo performance in front of the whole school!" Stephanie remembered how thrilled she was when Mr. Pollack, the band instructor, told her that she would be performing for the whole school during a special student gathering. The mayor of the city was visiting the school and Mr. Pollack decided that Stephanie would perform. Stephanie knew what a big deal it would be to have the mayor come to the performance!



The whole event was scheduled to take place after lunchtime. During lunch, as Stephanie was practicing her flute, a group of fellow band members gathered around to listen to her. Stephanie started to get nervous. "Do you guys mind? I'm trying to practice here!" As Stephanie grew more and more panicked, she started playing a few notes off key. Then, Maria came up to Stephanie. Maria was Stephanie's substitute; she would play if Stephanie became sick or couldn't make it to school for the performance. Maria and Stephanie were close friends. Maria came to wish Stephanie the best, but Stephanie thought she was coming to make fun of her. "Don't even say anything, Maria. I know what you think, but I'm not going to do badly in the most important performance of my life! I'm going to shine!" Maria thought Stephanie was talking a bit weirdly ever since Mr. Pollack had asked her to perform, but now she understood that Stephanie was just under a lot of pressure. "Why are you saying that, Stephanie? I just came to wish you the best before your performance." Stephanie stormed off shouting, "I can do without your wishes, Ms. Perfection! I just know that God is going to help me. I have been praying this whole week! Now all of you just leave me alone!"

Stephanie found a quiet place in the schoolyard and began to cry uncontrollably. Why did she act that way to her friends? There was no reason for her to be so mean. After all, Stephanie was sure God would help her in the performance. But then, why did she feel so badly? Was it because she skipped two Sabbaths to practice her flute? "No, it couldn't be that," thought Stephanie.

Soon, the big moment had arrived. The mayor was probably ten feet away from Stephanie. The principle announced to the whole school that Stephanie was going to perform. Everyone clapped and then there was silence. Stephanie began to get nervous again. She whispered, "God, You better have listened to all my prayers," as she stepped on stage. Stephanie began to play the flute beautifully. People clapped loudly during the performance. But near the end, she blew one note too hard and made a funny noise. A few people began to laugh. Stephanie didn't find it so funny, and she made more mistakes.

That day, Stephanie went home an extremely sad girl. She had finished the performance with a messy ending. Stephanie thought to herself. "Why did I make such a fool out of myself? Why did God let this happen to me?" The more Stephanie thought about her humiliation, the angrier she became. She began to blame God and cried. When Stephanie's mother came home, she saw the tears all over Stephanie's face. "What's wrong?" She asked Stephanie. All of a sudden, Stephanie burst into tears. "God never helps me when I need Him. I prayed for a whole week for today's performance." Stephanie's mother replied, "Stephanie, of course God loves you! Now calm down and think about it. Do you remember when I told you that God didn't want you to skip the Sabbath because of this performance? Maybe God wanted you to learn something from this experience!"





As Stephanie wiped away her tears, she understood what her mother meant. "I've been under too much pressure and I let that get in the way of my faith. I put too much emphasis on my own success and not enough attention on obeying God's commandments." Her mother agreed, "You're totally right. God, in His wisdom, sometimes allows us to be laid low so that we do not come to trust too much in our own abilities. We are prone to rely too heavily on ourselves and on our own ability to work things out the way we want them to go. When we are successful, we tend to forget God and take the credit for ourselves." Suddenly, Stephanie brightened up. She said, "I understand now! If God didn't love me, He wouldn't have given me this humbling experience. He didn't want me to lose sight of Him because of my own pride." Stephanie's mom nodded and chuckled at Stephanie's happy face. She said to Stephanie, "Lesson learned! Sometimes, God allows us to make mistakes and feel discouraged, but only because He wants us to grow through these bad experiences. He is always there for us when we turn back to Him. He wants to restore us and help us get back on track."

In the end, Stephanie learned that God's grace is enough in all situations. In one of her prayers, Stephanie asked for God's forgiveness for all the things she said. Suddenly, Stephanie felt the Holy Spirit come down upon her powerfully. Stephanie was happy in the joy of the Lord.

### **Discussion Questions**

**1. Why did Stephanie get so angry with everybody? What do you think she was thinking about?**

**2. Stephanie prayed all week for God to bless her even though it seems that He didn't bless her. Why do you think things happened like they did?**

**3. Do you ever feel like God isn't listening to your prayers? Share an experience. How can we always be thankful to God in all situations?**

### SUBMIT TO GOD'S WILL

Christians often wonder what God wants them to do concerning their desires and plans. It seems as though God's will is hidden in a buried treasure chest, and we have only small portions of the map to find its location. But is this true? In the Scriptures, we have all the guidance we need in order to live for Jesus Christ. God wants us to follow Him so that He can lead us step by step.

**Reference Verse:** 1 Thessalonians 5:16-18

**Scenario:** Lisa and her family moved to another state because of her father's new job. Lisa was having a tough time adjusting to her new school, and she missed her friends from her old school terribly. Even though Lisa didn't understand God's purpose for her to go through such a difficult change, Lisa remained joyful and prayed continually, giving thanks to God every day for keeping her family together safe and sound.



God has a perfect will for us. Even though at times we cannot see or understand it, we believe that with continuous \_\_\_\_\_, God will reveal it to us in His timing. Therefore, we should always be \_\_\_\_\_ and give \_\_\_\_\_ to God in all circumstances.

\*This is today's memory verse.

**Reference Verse:** Ephesians 5:17

**Scenario:** Jorge was really tempted during the exam to glance at Jeremy's last answer since it was the only answer of which he was unsure. Jorge really wanted to get all the answers right. He said a silent prayer to ask God to help him overcome his temptation. As Jorge realized that true wisdom is not reflected on his exam but on his decision to be honest, his urge to glance at Jeremy's answer disappeared. Jorge gave thanks to God.



We know that true wisdom from God allows us to understand and submit to God's will. It is \_\_\_\_\_ to choose our own path rather than follow God's directions. We should always pray for God's \_\_\_\_\_ so that we may understand His plan and perfect will for us.

**Reference Verse:** Romans 12:2

**Scenario:** Sophie's uncle served some fruit after dinner. Knowing that he was a fervent Buddhist, Sophie bravely asked her uncle if the fruit being served had been used for worshipping. Not surprisingly, he replied yes. Sophie politely rejected the fruit and explained to her uncle that she was a Christian. Surprised at Sophie's faith, her uncle began to find out more about God from Sophie.



To say "no" to someone is not always easy. It may strain the relationship, at least for a while. It may hurt. We may seem rude.

Friends may even exclude us. However, there are times when we

have to firmly say "no." A very good example for us today is that of Daniel's three friends: Shadrach, Meshach, and Abed-Nego. The king, Nebuchadnezzar, had built a golden statue and wanted all his subjects to bow down to it. Everyone in the country was doing it. But, these three youths knew that they should not conform to the \_\_\_\_\_. They refused to bow down to the statue, even at the risk of their lives. Their bravery to defy the king was \_\_\_\_\_ and \_\_\_\_\_ and in accordance with the perfect \_\_\_\_\_ of God. In the end, although they were thrown into a fiery furnace for holding on to their faith, God delivered them and they walked out of the furnace unscathed.

**Reference Verse:** Proverbs 3:5-6

**Scenario:** Natalie's parents couldn't afford to send her to a private school even though Natalie was so sure that she would have a much better learning experience there than in a public school. However, Natalie acknowledged that God had a perfect plan for her and that she should always rely on God. She knew that she needed to let Him guide her paths instead of leaning on her own understanding. She prayed that God could give her faith to trust in Him with all her heart.

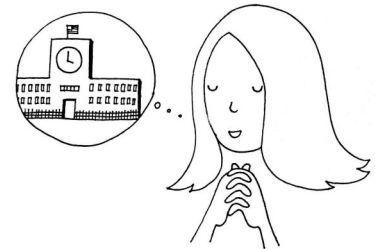

We don't know our future, but if we \_\_\_\_\_ in the Lord with all our \_\_\_\_\_, we can rest assured, knowing that He will Himself \_\_\_\_\_ all our paths. The key is to \_\_\_\_\_ Him in all we do and believe that His will, even at times beyond our own \_\_\_\_\_, is the best for us.

**After this lesson, how would you change the way you pray?**

---



---

\_\_\_\_\_’s Song of Thanksgiving

I thank the Lord for \_\_\_\_\_,  
for \_\_\_\_\_ and \_\_\_\_\_.

My heart is filled with joy and praise,  
Because He guides my way.

Thank you, Lord, for \_\_\_\_\_;

Thank you, Lord, for \_\_\_\_\_;

Thank you, Lord, for \_\_\_\_\_;

Thy will is always the best for me.

E2 Year 2 Book 2 Lesson 3—Seek to Do God's Will, and Be Thankful at All Times

# Homework Assignment

Name: \_\_\_\_\_ Parent signature: \_\_\_\_\_ Date: \_\_\_\_\_

Weekly Bible Reading: \_\_\_\_\_

**Bible Reading:** Check each box when you complete that day's reading.

**Prayer:** Check each box after you pray to God that day.

	Sun	Mon	Tue	Wed	Thu	Fri	Sat
Read							
Pray							

## What I Learned from the Bible This Week

1. \_\_\_\_\_  
 \_\_\_\_\_  
 \_\_\_\_\_
2. \_\_\_\_\_  
 \_\_\_\_\_  
 \_\_\_\_\_

## Memory Verse

Please write down this week's memory verse. **(1 Thessalonians 5:16-18)**

\_\_\_\_\_

## Fill In the Blank

1. When the ten lepers saw Jesus passing by, they lifted up their voices and said, " \_\_\_\_\_, \_\_\_\_\_, \_\_\_\_\_!" (Luke 17:13)
2. One of the lepers, when he saw that he was healed, returned, and with a loud voice glorified God, and \_\_\_\_\_, \_\_\_\_\_. He was a \_\_\_\_\_. (Luke 17:15-16)
3. Paul pleaded with the Lord \_\_\_\_\_ times that his affliction might depart from him. And God said to him, "My \_\_\_\_\_ is sufficient for you, for My \_\_\_\_\_ is made perfect in weakness." (2 Corinthians 12:8-9)

## Multiple Choice

4. \_\_\_\_: When the lepers realized that they were healed, they \_\_\_\_\_.
  - a. Thanked Jesus immediately
  - b. Went towards the village immediately so that they could show themselves to the priests
  - c. Asked Jesus from where His power had come
5. \_\_\_\_: Before God answered Paul's prayer, Paul prayed that \_\_\_\_\_ concerning his affliction.
  - a. God's will be done
  - b. He could glorify God with his physical suffering
  - c. God take away his pain
6. \_\_\_\_: God did not heal Paul because \_\_\_\_\_.
  - a. His will was for Paul to endure his pain and glorify His name through his suffering
  - b. Paul sinned against God before by persecuting Christians
  - c. It was not His timing yet





# LESSON 4

## WHAT IS PRAYER?

### OBJECTIVES

1. To learn about the purposes of prayer: praise, thanksgiving, confession, petition, and intercession.
2. To emphasize that prayer cultivates our relationship with God; the more students understand who God is, the more intimately and boldly they can pray.
3. To learn to talk to God every day, in every situation; God responds to simple faith.

### MEMORY VERSE

"Continue earnestly in prayer, being vigilant in it with thanksgiving."

(Colossians 4:2)

### PRAYER

1. Thank God for everything that happened in the past week.
2. Praise God for His creation and salvation. Praise God that we can come to worship Him in Spirit and in truth.
3. Thank God for His love, guidance and protection.



### Overview

#### 1. Types of Prayer

- Praise (Ex 15:2; Ex 15:11; Dt 10:21; Heb 13:15)
- Thanksgiving (1 Chr 16:7-36; Eph 5:19-20)
- Confession (1 Chr 21:17; Neh 1:4-11)
- Petition (Phil 4:6; Mt 6:25, 34, 38; 1 Sam 1:11)
- Intercession (Gen 18:23-25; Ex 32:11-14)

#### 2. Linking to the Ten Basic Beliefs—Jesus is the one true God.

#### 3. Life Application—Testimony: God's Love and Power

#### 4. Activity—Prayer Chain



### Background Knowledge for Teachers

#### Pray in Secret

"But you, when you pray, go into your room, and when you have shut your door, pray to your Father who is in the secret place; and your Father who sees in secret will reward you openly" (Mt 6:6). Jesus taught his disciples to pray in secret in their private rooms, using the Lord's Prayer as a humble response to the prayer of the Pharisees. Paul mentions that we need to "continue earnestly in prayer, being vigilant in it with thanksgiving" (Col 4:2) and to "pray without ceasing" (1 Th 5:17). "Now it came to pass in those days that He went out to the mountain to pray, and continued all night in prayer to God" (Lk 6:12). According to Luke, Jesus frequently sought to pray alone, for hours at a time. This is exactly what he was doing before he was betrayed in the garden of Gethsemane.

#### Receive God's Blessings through Prayer

The New Testament continually shows us that we receive God's blessings through prayer. "Ask, and it will be given to you; seek, and you will find; knock, and it will be opened to you. For everyone who asks receives, and he who seeks finds, and to him who knocks it will be opened. Or what man is there among you who, if his son asks for bread, will give him a stone? Or if he asks for a fish, will he give him a serpent? If you then, being evil, know how to give good gifts to your children, how much more will your Father who is in heaven give good things to those who ask Him" (Mt 7:7-11).



## Reaching Out to Your Students

1. Share with your students that God established prayer as an important way for us to communicate with Him. If we want to have a close relationship with Him, it starts with prayer. God's greatest desire is for us to have an intimate relationship with Him.
2. Elementary students are very joyful and happy to communicate with anyone who will listen to them. It is the same with God, let them know that God cares about their thoughts, their moods, their worries, their concerns and their needs. Use this introduction lesson to teach your students that God wants us to draw close to Him through prayer.



## Opener

5 Minutes

Do any of you have close friends with whom you like to talk and communicate? Have these friends ever sent you an invitation? It is exciting when we receive an invitation from our friends!

[Print out the invitation card sample on page 10 to show to the students. Show them how it says "A Special Invitation" on the front. Show and read to them the words on the inside.]

This is God's invitation to us! God has been sending many invitations asking us to meet Him! Guess where we are supposed to meet Him? (That's right, we meet with God in our prayers!) When we talk to God, it is called praying. How would you feel if your close friends told you to make an appointment every time you wanted to talk to him/her? (Sad.) God doesn't need us to make an appointment to talk to Him. He is always there for us!

### Activity: Handprint Prayer

**Materials:** Blank paper, markers

#### Instructions

1. Have each of the students trace one of their hands on a sheet of blank paper.
2. Over the thumb, write "**Praise**".
3. Tell the students to start their prayers by praising God using words or songs.
4. Over the first finger, write "**Thanksgiving**".
5. Tell the students that next, they can thank God for something He has done.
6. Over the second finger, write "**Confession**".
7. Tell the students that, in prayer, it's good to tell God the things they have done wrong.
8. Over the third finger, write "**Petition**".
9. Tell the students that next, they should ask God for the things they need, including forgiveness for the things they confessed.
10. Over the fourth finger, write "**Intercession**".
11. Tell the students that they can close their prayers by asking God to help others who need Him.
12. Put the picture up where it can be seen and remembered.



When your students have it memorized, they will have the knowledge of how to pray with them at all times.



## Vocabulary

**affliction:** a cause of mental or bodily pain, such as sickness, loss, etc.

**Alpha and Omega:** the beginning and the end

**confession:** an act of admitting something that you have done

**destiny:** something that is to happen or has happened to a particular person or thing

**intercession:** a prayer to God on behalf of another

**intimate:** a personally close feeling

**petition:** an earnest request to God

**salvation:** the act of saving from harm, risk, loss, destruction, etc.

**supplication:** a humble prayer to God

**ultimate:** last; furthest



## Bible Discovery & Spiritual Teaching

30-35 Minutes

[Write Matthew 6:9-13 (The Lord's Prayer) on the board. Ask the students to open the Bible to this passage and read it aloud, then ask them the following questions.]

1. Why did Jesus give the disciples this prayer?
2. Why did the disciples need to be taught how to pray?

God gives us so many examples of prayer in the Bible. We just read a prayer modeled by our Lord Jesus. Let's look in the Bible and find a few other prayers. We can see why people prayed and what they said in the prayers. This will help us understand more about what prayer is.

### FOR TEACHERS

Before you start the next section, hand out the Bible Discovery worksheet to the students. It contains all the passages mentioned in this lesson. Ask the students to fill out the worksheet as the lesson progresses. Each of the following five sections will reference related passages. When discussing each section, first have the students read each of the passages carefully and determine why the person was praying. At the conclusion of each section, ask the students to fill out their worksheets with the type of prayer they just learned.

### I. Praise

- Ex 15:2
- Ex 15:11
- Dt 10:21
- Heb 13:15

1. **Ex 15:2**—"The Lord is my strength and song, and He has become my salvation; He is my God, and I will praise Him; My father's God, and I will exalt Him."
2. **Ex 15:11**—"Who is like You, O Lord, among the gods? Who is like You, glorious in holiness, fearful in praises, doing wonders?"
3. **Dt 10:21**—"He is your praise, and He is your God, who has done for you these great and awesome things which your

eyes have seen."

4. **Heb 13:15**—"Therefore by Him let us continually offer the sacrifice of praise to God, that is, the fruit of our lips, giving thanks to His name."

### Praise God All the Time

Why do we need to praise God? We praise God because He is worthy of our praise (1 Chr 16:25; Rev 5:11-14). He is the King of Kings and Lord of Lords! He is the Alpha and Omega, the beginning and the end. He is our creator, provider, shepherd, healer, judge and much more. Did you know that as humans we were created by God to praise Him (Is 43:7; Mt 21:16)? As we draw near to Him in praise, He draws near to us (Jas 4:8).

Praise is also our ultimate destiny. When the Lord Jesus Christ returns again to earth, all creation—including prideful mankind—will recognize His glory and praise Him (Phil 2:9-11).

### II. Thanksgiving

Now, let's look at the second group of passages!

- 1 Chr 16:7-10
- Eph 5:19-20
- Ps 100:4-5

1. **1 Chr 16:7-10**—"On that day David first delivered this psalm into the hand of Asaph and his brethren, to thank the Lord: Oh, give thanks to the Lord! Call upon His name; make known His deeds among the peoples! Sing to Him, sing psalms to Him; talk of all His wondrous works! Glory in His holy name; let the hearts of those rejoice who seek the Lord!"
2. **Eph 5:19-20**—"Speaking to one another in psalms and hymns and spiritual songs, singing and making melody in your heart to the Lord, giving thanks always for all things to God the Father in the name of our Lord Jesus Christ."

3. **Ps 100:4-5**—“Enter into His gates with thanksgiving, and into His courts with praise. Be thankful to Him, and bless His name. For the Lord is good; His mercy is everlasting, and His truth endures to all generations.”

These passages teach us that we need to...

### Thank God All the Time

Perhaps the most neglected type of prayer is the prayer of thanksgiving. Saying grace before eating a meal is a good example of a prayer of thanksgiving. We should get into the habit of thanking God throughout the day for the good things that happen to us and to others. We ask God for a lot of things, but at the end of the day, we need to thank Him no matter what has happened.

Prayers of thanksgiving are proclaimed throughout the Bible. In 1 Chronicles 16:7-10, David's song is an excellent example of a prayer that contains the five elements included in true thanksgiving:

- **Remembering** what God has done for us.
- **Telling** others about what God has done.
- **Singing** to God.
- **Talking** and showing God's glory to others.
- **Rejoicing** in the Lord.

Psalm 100 is a vow of thanksgiving. Students, there are 150 psalms in the book of Psalm, and David wrote 73 of them. Through this collection of prayers and songs, David expresses his heartfelt feelings from deep within his soul. In the psalms, we can read prayers of thanks for: an answered prayer, deliverance from difficulties, God's greatness, His protection, His enduring mercy, and His never-ending love. God still provides all of those things for us today.

Prayers of thanksgiving are indeed important as we all have reasons to be thankful. In fact, we are reminded to “pray without ceasing, in everything give thanks; for this is the will of God in Christ Jesus for you” (1 Th 5:17-18). We can be thankful for who God is and for the opportunity He gives us to turn to Him in all situations, both good and bad. God is always there for us. Our sincere prayers let Him know that we are thankful for that. Prayers of thanksgiving should be a continuous part of our everyday lives.

### III. Confession

Now, let's look at some more passages.

- 1 Chr 21:17
- Neh 1:4-6

1. **1 Chr 21:17**—“And David said to God, “Was it not I who commanded the people to be numbered? I am the one who has sinned and done evil indeed; but these sheep, what have they done? Let Your hand, I pray, O

Lord my God, be against me and my father's house, but not against Your people that they should be plagued.”

2. **Neh 1:4-6**—“So it was, when I heard these words, that I sat down and wept, and mourned for many days; I was fasting and praying before the God of heaven. And I said: ‘I pray, Lord God of heaven, O great and awesome God, You who keep Your covenant and mercy with those who love You and observe Your commandments, please let Your ear be attentive and Your eyes open, that You may hear the prayer of Your servant which I pray before You now, day and night, for the children of Israel Your servants, and confess the sins of the children of Israel which we have sinned against You. Both my father's house and I have sinned.’”

Boys and girls, we can see that each of these verses is an example of a...

### Prayer of Confession

We just read David's prayer for Jerusalem not to be destroyed and Nehemiah's prayer of confession for Israel's sin.

The Greek word for sin as used in the New Testament translates to “missing the mark” or “missing the target.” The prayer for confession of sins is important because God has called us to come to Him, to seek His forgiveness. Sin separates us from God; He is perfect and cannot tolerate the presence of sin. We need to ask God to forgive us of the sins we don't know we committed.

“He who covers his sins will not prosper, but whoever confesses and forsakes them will have mercy” (Pr 28:13).

That's why, when we confess our sins in prayer, we need to have a contrite heart. Many members shed tears during prayer when confessing. That's a very clear sign that they are confessing from the core of their hearts and not just superficially.

**What do we confess?** Some examples:

- Pride, arrogance
- Jealousy, wicked thoughts, hatred
- Idolatry, anything more important than God to you
- Lustful thoughts (e.g., bad music or websites)

**Steps to confession:**

1. Have a humble heart (Mt 11:28-30)
2. Tell God exactly what you need to confess; acknowledge it and ask for forgiveness (Dan 9:4-19; Ps 32:5-7)
3. Confessing our sins to one another offers us accountability, allowing us to pray effectively for one another (Jas 5:16)



#### IV. Petition

Next, let's turn to the following verses.

- Phil 4:6
- 1 Sam 1:11

These verses are teaching us about the...

##### Prayer of Petition

Prayers of petition are the type of prayer with which we are most familiar. In them, we ask God for the things we need—both physical and spiritual needs. In Matthew 6:25, 28, 34, Jesus repeatedly assured us not to worry. In terms of our relationship with our heavenly Father, God is teaching us not to be anxious.

1. **Phil 4:6**—"Be anxious for nothing, but in everything by prayer and supplication, with thanksgiving, let your requests be made known to God."
2. **1 Sam 1:11**—"Then she made a vow and said, 'O Lord of hosts, if You will indeed look on the affliction of Your maidservant and remember me, and not forget Your maidservant, but will give Your maidservant a male child, then I will give him to the Lord all the days of his life, and no razor shall come upon his head.'"

In Philippians 4:6, Paul wrote [ask students to read the verse aloud with you], "Be anxious for nothing, but in everything by prayer and supplication, with thanksgiving, let your requests be made known to God." God doesn't want us to worry about things. God wants us to tell Him what we are facing and what our needs are. He wants to take care of our needs. Doesn't It feel great to know that God cares about us so much that He listens to us all the time?

In her prayer, Hannah asked and wept in anguish for a child. After this prayer, Hannah no longer had a sad expression on her face because she believed that God would answer her prayer (1 Sam 1:18). This is indeed great faith.

When we petition, we are asking God, who loves us very much, for something that we believe is good for ourselves. Remember, God wants us to bring our problems and worries to Him in prayer knowing that He will always hear and answer those prayers. [Point out to the students that God's answer might not be exactly what we are asking for, but that God will always give us what we need. The motivation is very important.]

We can also pray about things that cause pain and suffering in our world, including environmental destruction. Additionally, we can also pray for help in our schoolwork, for a safe trip, and for peace in our families and the world.

#### Some prayers from students:

- Dear Heavenly Father, sometimes, I get scared and I feel alone at school. Please let me know that You are here. Comfort and protect me.
- Dear Heavenly Father, I need to pray for wisdom to learn new things at school. I want to do well in all my classes.
- Dear Heavenly Father, I would like to know the plans that You have for me in the future. Please show me the way and reveal my gifts so that I can seek Your kingdom.
- Dear Heavenly Father, some of my friends are doing bad things after school. Please give me the courage to stand up and say no to their pressure. I don't want to do the things that they do. I need You every minute. Please give me the wisdom to discern between right and wrong. Thank You, God.

#### V. Intercession

Last but not least, let's study these two passages in the Bible.

- Gen 18:23-25
- Ex 32:11-14

1. **Gen 18:23-24**—"And Abraham came near and said, 'Would You also destroy the righteous with the wicked? Suppose there were fifty righteous within the city; would You also destroy the place and not spare it for the fifty righteous that were in it?'"
2. **Ex 32:12**—"Why should the Egyptians speak, and say, 'He brought them out to harm them, to kill them in the mountains, and to consume them from the face of the earth'? Turn from Your fierce wrath, and relent from this harm to Your people."

We can conclude that each of these passages is a...

##### Prayer of Intercession

This prayer is spoken on the behalf of others. This is a way to help students know that their prayer can be a source of blessing upon others, the church, and our world. Such prayer can bring us great strength and courage. In the passages we just studied, Abraham interceded for the people in Sodom and for Lot, while Moses interceded for God's people.

Paul said to Timothy, "Therefore I exhort first of all that supplications, prayers, intercessions, and giving of thanks be made for all men, for kings and all who are in authority, that we may lead a quiet and peaceable life in all godliness and reverence. For this is good and acceptable in the sight of God our Savior" (1 Tim 2:1-3).

Some other examples in the Bible [have students read the passages]:

1. The Lord prayed for Peter (Lk 22:32).
2. The Lord prayed for the twelve disciples and for the churches in the future (Jn 17:9, 20).
3. Paul prayed for the believers and asked the believers to pray for him as well (Rom 15:30-33; Eph 3:1, 14-19; 6:18-20; Col 1:3; 4:2-4).
4. Moses prayed for the people (Ex 17:8-13; 32:7-14).
5. Samuel prayed for the nation (1 Sam 7:5-11, 13).

Likewise, we can pray for:

1. Church work and church members
2. Salvation for someone you care about and love
3. Missionary and ministry work around the world
4. Our country and president
5. Soldiers at war

Therefore, remember to always pray for others. This is good and pleasing to God because God wants His people to live peaceful and quiet lives, free to worship God and live for Him. This type of prayer is effective.



## Linking to the Ten Basic Beliefs

*2-5 Minutes*

### Jesus is the one true God.

Dear students, today we studied five different types of prayer: praise, thanksgiving, confession, petition, and intercession. How is prayer related to the Ten Basic Beliefs? As we know, one of our basic beliefs is that Jesus is the one true God. Prayer cultivates our relationship with God. The more you understand who God is and what He can do, the more intimately and boldly you can pray.

God is the giver of life! He created you in His image and He wants you to praise Him and give thanks to Him at all times. Not only that, when you return to God, confess, and entrust your life to God, He will create a new heart within you. Prayer is not simply a ritual that you do before a meal or at bedtime. It involves a very personal relationship with God.

So, let's continue to share our thoughts with God because He is the one true God that is always there for us. He is the only one who can truly help us through all of our problems, so let's continue talking to God in every situation. Through constant prayer, we will get to know Him better and live a meaningful prayer life as well!



## Check for Understanding

*5 Minutes*

As mentioned before, there are different types of prayer. Write the following words on the board and ask the students to use their own words to write what each one means: **Praise; Thanksgiving; Confession; Petition; Intercession.**

- **Praise:** We praise God for who He is, for His character and also for His actions.
- **Thanksgiving:** We thank God for what He has done for us. We can thank Him both for blessings seen and those yet to be seen. It is key to our faith and we should always give thanks (1 Th 5:18).
- **Confession:** We tell God about our sins.
- **Petition:** We ask God for the things we need. Jesus said, "Ask, and it will be given to you" (Mt 7:7). We are commanded to ask with the right motive.
- **Intercession:** We intercede for the needs of others. We focus not on praying for ourselves, but for others.





## Life Application

10 Minutes

### God's Love and Power

[Hand out the Life Application worksheet. Open with the introduction below, and then read the testimony with the students. Afterwards, discuss the questions as a class.]

The following is a testimony from Br. Paul Gau about God's love and power. Through this testimony, the students will learn that our God is an amazing God who can perform miracles, but most importantly that He is a loving God. They will also learn about the prayers of intercession and petition and their effectiveness.

#### Life Application/Discussion Questions

1. **What did the church members do to show their love to this family?** They fasted and prayed.
2. **What types of prayer did the church members offer?** Prayers of petition and intercession.
3. **Why are intercessory prayers so effective?** Their family saw the love their fellow brothers and sisters had for them and were touched by it. More importantly, God saw the love that the members had for Br. Gau's family and answered their prayers. Br. Gau's family witnessed God's power through the baptism and Grace's blood count continued to increase and now she has completely recovered.



## Activity

### Prayer Chain

10-15 Minutes

**Objective:** To remind students to pray for one another.

#### Materials

- 1" x 7" strips of colored construction paper
- Markers
- Glue or stapler

**Note to Teachers:** Prepare the strips well ahead of class time. Be sure to have plenty of extras on hand.

#### Instructions

1. Pass out one strip of construction paper to each student. This strip will later become a link in the prayer chain.
2. Have students write their name on the strip of construction paper.
3. Ask them to also write the names of other members or people for whom they would like to pray.  
Some suggestions are: people who need special care, their grandparents, their neighbors, people who are sick, or people who are sad.
4. Ask students to share what they have written on their paper. After each student has shared, the chain can be created.
5. Bend each strip into a circle so that it creates a chain link.
6. Add each link to the prayer chain by taping or stapling the ends of the link together.
7. Display the prayer chain somewhere in the classroom where the students can see it and be reminded to pray for others.

Encourage the students that the Spirit of God helps us in our prayers and so they should always remember to pray for others because God will help them help others. End the activity by reading this verse aloud together with the students. "Praying always with all prayer and supplication in the Spirit, being watchful to this end with all perseverance and supplication for all the saints" (Eph 6:18).

**Invitation Sample**

This is to be used in the Opener section. Please print and cut this out, and then fold it in half to show to the students.

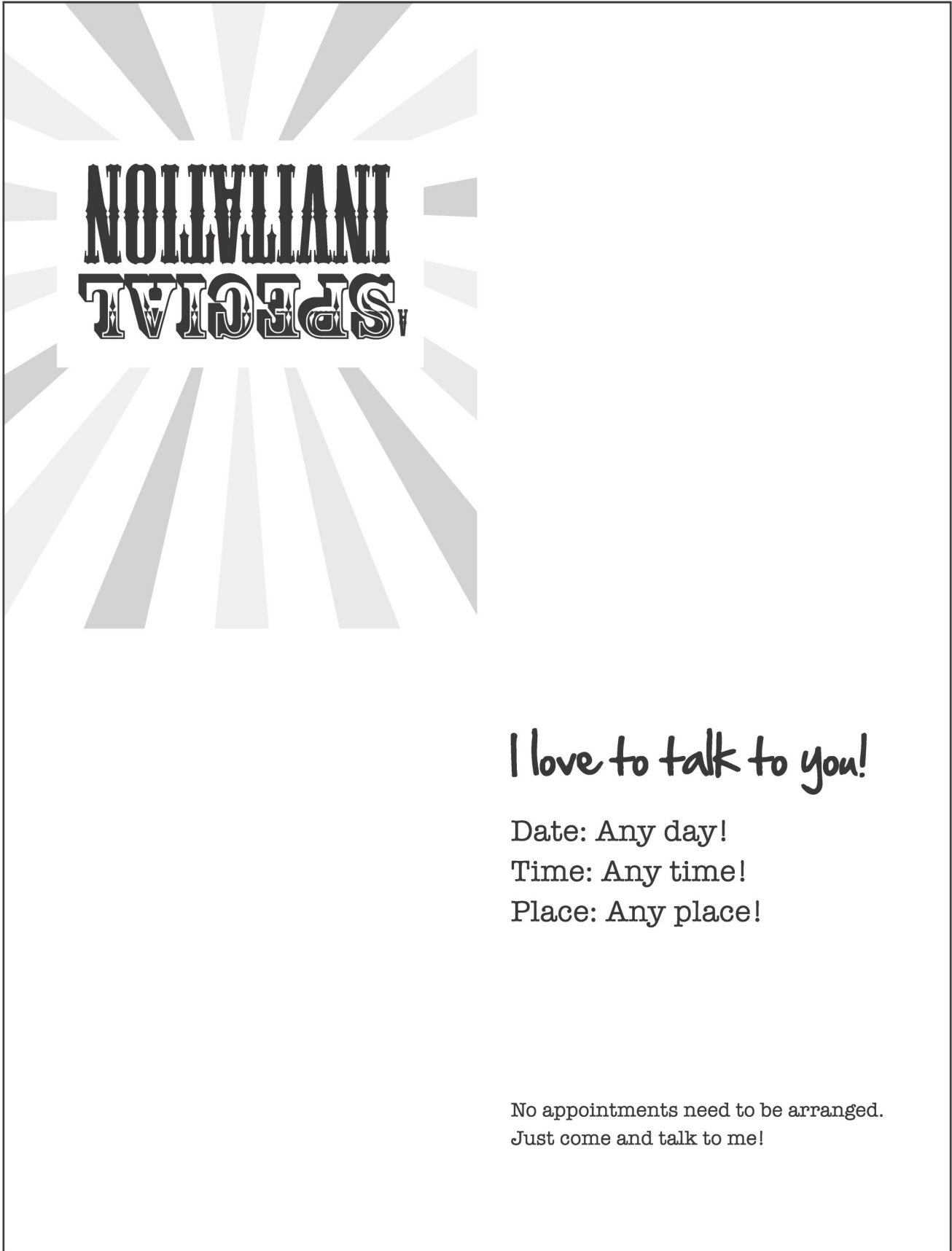

**UNDERSTANDING PRAYER**

PASSAGES	TYPE OF PRAYER
<ul style="list-style-type: none"> <li>• Exodus 15:2</li> <li>• Exodus 15:11</li> <li>• Deuteronomy 10:21</li> <li>• Hebrews 13:15</li> </ul>	
<ul style="list-style-type: none"> <li>• 1 Chronicles 16:7-10</li> <li>• Ephesians 5:19-20</li> <li>• Psalm 100:4-5</li> </ul>	
<ul style="list-style-type: none"> <li>• 1 Chronicles 21:17</li> <li>• Nehemiah 1:4-6</li> </ul>	
<ul style="list-style-type: none"> <li>• Philippians 4:6</li> <li>• 1 Samuel 1:11</li> </ul>	
<ul style="list-style-type: none"> <li>• Genesis 18:23-25</li> <li>• Exodus 32:11-14</li> </ul>	

## GOD'S LOVE AND POWER

Hallelujah, in the name of our Lord Jesus Christ I would like to testify about our family's experiences of God's great love and power.

### **Stricken Suddenly by a Rare and Life-threatening Disease**

In June 1991, my 14-year old daughter Grace suddenly felt tired and became pale. Since she had always been healthy and rarely fell ill, I was surprised by her condition and took her to see the doctor. The doctor found that her blood count was dangerously low and he immediately transferred her to the state medical center for further tests. The test results showed that Grace had aplastic anemia. This is a rare disease that occurs mostly in young people between the ages of 15 to 30. Even though medical science has attributed the major causes of this disease to chemicals, radiation and viruses, in over 80% of the cases, the exact cause cannot be identified. This disease suppresses or even completely stops the production of red blood cells in the bone marrow, creating severe anemia. This disease is not cancer, but the decreasing red cells in the blood makes it equally, if not more, life-threatening. The doctor explained that although treatment was available, its effectiveness in children was much lower than in adults (approximately 10% to 20% versus 50% respectively).

### **A Bone Marrow Transplant Was Needed**

Nevertheless, Grace remained in the medical center for treatment and the doctor told us that the outcome would be known within two to three weeks. At the same time, a bone marrow match test was conducted on my family members and close relatives in preparation for a bone marrow transplant in the event that the treatment failed. A bone marrow transplant is one of the most expensive and painful medical operations, requiring six months of painful recuperation. At the medical center, Grace's blood had to be extracted daily to test for her response to the treatment, but six weeks later, her condition did not improve. We even consulted the world's leading medical authority in this field, but he could only give us a 50% transplant success rate.

### **The Calling of God's Love and Mercy**

Since Grace had always been very healthy, we believed that her illness might have come with God's goodwill to call us back to Him and to His church. When I came to study in the US, our church had not been established yet. Even now the nearest church is three states away from where we live. So during my stay in the US, I had not been regularly attending church services. In addition, although from time to time we had Bible studies and prayers at home, the rest of my family members had yet to receive baptism and become part of God's family. This in itself was a transgression against God's love and glory. We knew God is love and would forgive us if we sincerely and deeply repented of our transgressions. So during Grace's illness, we prayed long and hard to God daily for His forgiveness, and my family members resolved to receive baptism in His holy name. At the same time we also asked our relatives and church members to pray for us.

### **Fasting Prayers and the Brethren's Love**

At this time, a church minister invited us to attend the forthcoming youth and spiritual convocation in our church in Elizabeth, New Jersey. Through the help and arrangement of our ministers and relatives, we were able to attend despite the doctors' reservations on Grace's condition. At the convocation, we were deeply touched to learn that during the two weeks preceding our arrival, the church had been fasting and praying for us. With so many loving brothers' and sisters' intercession, we believed God would answer their prayers of faith and love. Not only did God not reject us, we also received showers of blessings beyond our greatest expectations. My wife received the most precious Holy Spirit during the first day of fasting prayer. On the second day Grace also received the Holy Spirit. The night before my family was baptized, many church members remained in church after the evening evangelical service to pray beyond midnight for the baptism. During the baptism, both my wife and Grace saw the vision of the blood of Jesus Christ. After the baptism, the paleness in Grace's face and the coldness in her hands disappeared.

### **Miracle**

We had to return to Mississippi the morning following baptism because Grace still needed weekly transfusions of blood at the medical center. From the airport, we went directly to the medical center for the pre-scheduled test. Miraculously, Grace's blood count actually increased! God had restored her bone marrow's normal production of red blood cells. Having seen God's power, our faith grew stronger and Grace stopped taking the prescribed medicine. Instead, we relied on praying harder every day, knowing that many brothers and sisters in Christ were doing the same. We continued with our morning fasting prayer for three months. Thank God, Grace's blood count continued to increase and now she has completely recovered.

By the love of God, during these past five years, Grace has been leading a healthy life filled with physical activities. She has also participated in numerous spiritual convocations and seminars, and visited many churches in Taiwan and Hong Kong. She is currently pursuing her university education at Georgetown University in Washington D.C.

### God—the Greatest Physician

Though we had a belief in God in the past, through Grace's illness we have experienced Him. From this extraordinary incident, there are several points deeply felt by us that we would like to share:

- Our God is the sole source of life. He is also the greatest physician. He created not only all life in the universe, but every cell in our body. Only He has the absolute power and authority to heal all diseases and restore health and life. Believing in Him is the foundation and the beginning of all healing (Jn 11:25; Mt 8:14-16, 9:35).
- Deep and earnest prayer is the foundation of our daily faith and spiritual strength.
- The greatness of God's love and power is beyond human comprehension. If we come to Him with a repentant heart and a sincere, humble faith, He will eventually shower His mercy and grace upon us (Mt 7:7; Lk 15:17-32).
- Our health, peace and achievement come from His blessing. Without it, humans labor in vain. The world's knowledge, wealth and fame are temporary and cannot help when real trouble comes. God and our life of faith are most fundamental and should take priority over everything else (Mt 6:33; Ps 127:1).

May all glory, power, and praise be given to our Lord forever. Amen.

\* \* \* \* \*

### Life Application/Discussion Questions

1. What did the church members do to show their love to this family?

2. What types of prayer did the church members offer?

3. Why are intercessory prayers so effective?



E2 Year 2 Book 2 Lesson 4—What Is Prayer?

# Homework Assignment

Name: \_\_\_\_\_ Parent signature: \_\_\_\_\_ Date: \_\_\_\_\_

Weekly Bible Reading: \_\_\_\_\_

**Bible Reading:** Check each box when you complete that day's reading.

**Prayer:** Check each box after you pray to God that day.

	Sun	Mon	Tue	Wed	Thu	Fri	Sat
Read							
Pray							

## What I Learned from the Bible This Week

1. \_\_\_\_\_  
 \_\_\_\_\_  
 \_\_\_\_\_
2. \_\_\_\_\_  
 \_\_\_\_\_  
 \_\_\_\_\_

## Memory Verse

Please write down this week's memory verse. **(1 John 5:14)**

\_\_\_\_\_

## Understanding Prayer

**Instructions:** In this lesson, we learned about five different types of prayer. Please write down a prayer for each type of prayer listed below.

1. Praise

2. Thanksgiving

3. Confession

4. Petition

5. Intercession



# LESSON 5

## THE LORD'S PRAYER (PART 1)

### OBJECTIVES

1. To understand that God wants an intimate relationship with us.
2. To strive to put God's teachings into practice, for God's name deserves our honor.
3. To find comfort knowing that God has a master purpose for the world and a purpose for our lives.
4. To build up trust in God, for He can meet all our needs.

### MEMORY VERSE

"Be anxious for nothing, but in everything by prayer and supplication, with thanksgiving, let your requests be made known to God."

(Philippians 4:6)

### PRAYER

*Prior to the opening prayer, you can quiz the students as to the purpose of praying to God. Use any generic phrases or answers they may say (e.g., to thank God, to repent, for guidance) to draw out how God has done this for them in the past week. Tell them that prayers can be a time to reflect on specific events, needs, or sins and explain how this will help them put their prayer "into action."*



### Overview

#### 1. The Lord's Prayer: Part 1 (Mt 6:5-11; Lk 11:1-3)

- Relationship: "Our Father..." (Rom 8:14-16; cf. Acts 17:27-28; Mt 7:7-11)
- Name: "Hallowed be Thy Name" (Acts 4:12; Phil 2:9-11; cf. 1 Pet 1:15; Lk 1:31-32)
- Purpose: "Thy will be done..." (Lk 17:20-21; cf. Rom 12:1; Col 3:15; Rom 8:28)
- Needs: "Give us this day our daily bread..." (Mt 6:25-34; Prov 30:7-9)

#### 2. Linking to the Ten Basic Beliefs—Our Heavenly Father to whom we pray is the one true God.

#### 3. Life Application

- A Father and His Children
- Praying to Praise and Not Simply Out of Need

#### 4. Activity

- P.R.A.Y.
- In Your Own Words



### Background Knowledge for Teachers

The next two lessons will focus on teachings from the Lord's Prayer. This lesson will focus on the first half of the prayer. The two gospel books in which it is found differ slightly in the focus and context through which Jesus taught the Lord's Prayer. This does not necessarily indicate that Jesus taught this prayer on multiple occasions, but that the writers saw different significances in the teaching of the prayer. In gaining a better exegetical understanding of the relevant passages, we as teachers will be able to deliver the same teachings to our students in accordance with the will of our Lord Jesus.

#### "In this manner, therefore, pray..."

The passage in the Gospel of Matthew is directly preceded by warnings to pray in secret and not in wealth of words for the sake of showing others how zealous we are. Our Father already knows the things we need before we even ask (Mt 6:7-8). This, however, does not mean that there is no need to pray since God already knows everything. The Lord's Prayer is a depiction of our relationship of faith with God and how He seeks for us to communicate with Him (Phil 4:6). Therefore, our prayers should not just comprise a list of requests or an action of showing others how zealous we are—the manner in which the Pharisees prayed. Instead, our prayers should be a process of growth taking place in us that will allow us to better understand God and grow in faith and love (Eph 3:14-19).

**Teach us to pray**

At the same time, in the Gospel of Luke, the teaching of the Lord's Prayer is a reminder of how lowly we are and that we need to be taught by our Lord. Our prayers should be reminders each time of how lowly and unworthy we are before our Creator and that we should never exalt ourselves no matter how much success we have in this world (Ps 8:3-4). Rather, in our prayers we are relying on Him and this is why the passage directly following the Lord's Prayer speaks of praying for the Holy Spirit (Lk 11:13). It is the Holy Spirit who teaches us and reminds us of the words of God (Jn 14:26).

**Reaching Out to Your Students**

Many of your students at this level have the Lord's Prayer memorized but do not yet fully understand the words that they recite. Emphasize to the students that when they recite the Lord's Prayer, it's not about reciting it perfectly or reciting it as fast as they can. Instead, there are simple life applications in the Lord's Prayer that they must try to grasp.

The Lord's Prayer does not only have an effect when it is recited at the end of a prayer session. Your students are at an age where prayer can carry more personal significance. They may rely on prayers when they are sick, in trouble, or sad. You can teach the students how to think of the Lord's Prayer during their prayers, expanding the content of their prayers beyond just a supplication. In doing so, students can better understand how prayer is a significant part of their relationship with God.

**Opener***5 Minutes*

Do you talk often with your father? How do you talk to your father? We know from the Bible that a father is the head of a household. Students, please brainstorm the different things you talk to your father about. [Give students a minute to come up with answers, and then hand out index cards with the following scenarios.]

- You accidentally scratched your dad's brand new car when riding your bicycle.
- You have a difficult homework problem that you don't know how to answer.
- You've caught the flu and feel so sick you can hardly move.
- Your dad just bought you a brand new computer.
- Your parents are talking about your grades and extracurricular activities and ask you to leave the table, as they're having a "grown up talk."

Please read the scenario and think of how you would speak to your father in this situation. What emotions do you feel? Happy? Sad? Scared? What would you say? [Place a photo of a generic father figure on the board, and ask each student to act out how they would speak to their "father."]

Boys and girls, today we also have a heavenly Father. He is God. How do we talk to Him? [Allow students to answer.] We may pray to God about many things. Sometimes our prayers can be that of praise, of repentance, of supplication or ones in which we simply try to better understand our heavenly Father. While Jesus was on earth, He taught His disciples how to pray. He didn't want His disciples to pray for the purpose of only asking for things they wanted, nor did He want them to pray just to show others how good and faithful they were. Does anyone know how Jesus taught His disciples how to pray?



## Vocabulary

**hallowed:** to be treated as holy

**heir:** someone who inherits land, property, or possessions from their forefathers to continue the family line

**praise:** an act of worship; to show admiration

**yield:** to give in, accept, or submit

**sovereign:** supreme ruler over all; above all



## Bible Discovery & Spiritual Teaching

30-35 Minutes

### FOR TEACHERS

Please hand out the Bible Discovery worksheet and ask the students to fill it out as the lesson progresses. Instruct students to write down the summarized bullet points at the end of each section, as well as the corresponding Bible verses. Keep a copy for yourself as reference.

Students, let us start off by writing the Lord's Prayer together. Let us turn to **Matthew 6:9-13**. [Ask students to read the passage aloud, and then write it down on the worksheet.] Now, using a pencil, I want you each to lightly underline each word you think is important or the main focus in each line. Then, using a highlighter, highlight the following words on your worksheet. [On the board, write: "Father, Heaven, Hallowed, Name, Kingdom, Will, Daily, Bread" .]

Now, let us try to understand what Jesus wanted to teach us about prayer when He taught His disciples this prayer.

### "Our Father in heaven"

At the beginning of the lesson, I explained that God is like a father. In pairs, quickly discuss these two questions:

1. What do your parents do for you?
2. How often do you talk to your parents?

When Jesus taught this prayer, He said that God isn't just any ordinary father—He is our heavenly Father. What does that signify for us? Let us turn to **Romans 8:14-16**. Every one of us who has been baptized and received the promised Holy Spirit is a child of God, and He is our Father. In fact, the Bible also says that when we become children of God, we become heirs and can inherit something wonderful. What kind of things can we inherit from God? (The heavenly kingdom and eternal life.) This is why having God as our Father is the best thing for which we could ask. When we pray, we don't need to worry about anything because we are talking to a Father who has power over everything. Moreover, He loves us very much! He is like our parents, but even more powerful—God will do everything to take care of us. That is why Jesus started

the prayer by saying, "our Father in heaven." He was describing how close God is to each and every one of us.

### Summary

- God is our heavenly Father.
- He will always take care of us.
- As our Father, He always wants to talk with us.

### "Hallowed be Your name"

The next line says, "Hallowed be Your name." Does anyone know what "hallowed" means? It means, "treated as holy," and only one name in the whole world and history of mankind is holy and all-powerful. Let us read a few verses. [Ask students to turn to Acts 4:12, Philippians 2:9-11, and Luke 1:31-32.]

How do we normally start our prayers? (In the name of our Lord Jesus.) Every time we say this, it should remind us that God is all-powerful and that He came and died for us. Since His name is holy, let us ask ourselves two questions.

1. What should we do in the name of Jesus? (Preach, worship, overcome any weaknesses or sins, live a pure and holy life, etc.)
2. What shouldn't we do in the name of Jesus? (Use it casually in conversation for jokes, or regard it as any other name.)

When we pray to God, we are praying to a holy being. So, by asking ourselves the two questions above, we can better understand for what we should and shouldn't pray.

### Summary

- God's name is holy, and we should not use His name casually or in vain.
- Likewise, whatever we pray about in God's name should be holy.

### FOR TEACHERS

If class time allows, you can choose to discuss the following question: How can we work towards having God's name hallowed?

Allow students to answer freely. Touch upon the following actions if they haven't already been brought up.

1. By acting in accordance to the Bible's teachings.
2. By preaching the gospel to more people so that more people can come to obey God and glorify His name.
3. By maintaining peace in church and helping out with church work so that the church as a whole can bring honor to God's name.

**“Your kingdom come. Your will be done on earth as it is in heaven.”**

God is our heavenly Father, but He is much more than just our Father. When Jesus taught this next line in the Lord's Prayer, it showed another role God plays in our lives. Can anyone guess what role that is? (King.) Every king needs a place over which to rule. Where is God's kingdom today? (In our hearts, at church, heaven, etc.)

We know that God rules in heaven and that He guides the church by His Spirit, but the focus of this lesson is: does God rule over our hearts today? Let's read **Luke 17:20-21**. This verse tells us that the kingdom of God is within us. However, how do we know that God rules over our hearts? We can tell through our actions and speech, through the way that we act, talk, and walk. If God is King, this means that He has sovereign power to do what He wills. This is very important to learn, because as King, God is very wise. He has a master plan for all of us and knows exactly what He wants each of us to do. So, when we say this line in prayer, we are asking God to work in our lives. Regardless of the outcome, good or bad, we will yield to His plan and know that He has His special way for us.

Let's continue by reading **Romans 8:28**. If we allow God to be King in our lives, nothing can mess up our lives. Even when we face difficulties and hardships, we can be assured that the ending will be for our own good. There is a condition for everything to work out for our own good, though. We must first love God and do according to His good plans for us.

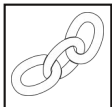

## Linking to the Ten Basic Beliefs

2-5 Minutes

### One true God

Our heavenly Father to whom we pray is the one true God. Omniscient, omnipresent, and omnipotent, He is the one who created the heavens and the earth. He is the only who can answer our prayers, but we must first pray in the correct manner, as taught in the Lord's Prayer.

### Summary

- God is King in heaven, church, and our hearts.
- Since God is King, we have to submit to His plan during both smooth times and rough times in our lives.

### “Give us this day our daily bread.”

The last line we are learning today is a line that all of us say during our prayers every day. Students, raise your hands if you say grace before you eat. Share with your classmate next to you what you pray about when you say grace.

Other than food, do we give thanks to God for everything He has provided for us? “Our daily bread” here does not refer only to food or even just physical sustenance. God takes care of all our needs: physical, emotional, and spiritual. This part of the Lord's Prayer should be a good teaching to us that we should entrust the whole of our lives to Him.

Matthew 6:25-34 tells us not to worry about our lives, or about what to eat or drink. God has promised to provide for all of our needs. Many times in life, we're unhappy because of our greed, not our need. Consider what we have; has not God provided for all that we really need?

We thank God for the many things that God has given us. Since God has given us so much “daily bread,” there is one thing we need to make sure of when we pray. Let's read **Proverbs 30:7-9**. No matter how much or how little daily bread we are given, we should never forget God because of our abundance or complain to God because of our need.

### Summary

- God supplies us with all our physical needs, so we must trust in Him.
- Be thankful for however much or little we are given.



## Check for Understanding

5 Minutes

- 1. What was the purpose of the Lord's Prayer?** To teach the disciples the way to pray and talk to God. To teach the disciples that praying was not done just to show others how spiritual they were.
- 2. Today, what should we do when we recite the Lord's Prayer in our prayers?** We should reflect on each line and its teachings, as well as think of what God has done for us in our lives.
- 3. Evenly divide the students into four groups. Ask them to choose one line from the Lord's Prayer. They will discuss in a group and present to the class how that line of the Lord's Prayer applies to their lives today.**



## Life Application

10 Minutes

In the Lord's Prayer, Jesus was teaching us the *manner* in which we should pray.

### 1. A Father and His Children

How often do you talk to your parents? What do you talk to them about? If a child only goes to their parents when they need something, do you think this is a healthy family?

1 Peter 5:7b says that God cares for us. He is constantly and sleeplessly watching over us. Like a mother hen, He covers us with His wings and gathers us (Ps 91:4; Lk 13:34). We need to talk to God as family members having a good chat with one another do—every day. We must not simply seek Him out when we need Him, but rather tell Him all the little details in our lives. Such a ceaseless, prayerful life will help us build a strong habit of praying for when we are in trouble.

[Hand out Life Application Worksheet #1, go over the instructions, and give students time to complete it. If you would like, you may call on volunteers to share their prayers when everyone has finished.]

### 2. Praying to Praise and Not Simply Out of Need

Normally, we always pray for two things:

1. For help with a physical need
2. For the Holy Spirit

These two are very important for us as Christians. But, in the Lord's Prayer, Jesus was teaching us that prayers are more than just requests to God. When we sing hymns to God, what do we feel? We feel joy, because we're praising Him, saying how great He is. We should feel the same when we pray. If we always feel sad or tired when we have to "bend our knees" in prayer, then it will not be something desirable for us.

Philippians 1:3-4 teaches us that Paul was joyful in prayer, always thanking God. If He is truly King in our hearts and has provided for our every need, we should think and meditate on all of these events that God has helped us with in our prayers. Play the events back as if you're watching an old video, and the gratefulness and peace you feel will turn into praise to God in prayer. Also, when we do this and reflect on God's power, it will make us more focused in prayers. This way, praying for the Holy Spirit and for some of our needs won't feel as difficult or like a chore anymore. [See Activity #1 for further reiteration of this point.]





## Activity

### 1. P.R.A.Y.

10-15 Minutes

**Objective:** To teach students the many wonderful purposes of prayer.

#### Materials

- Construction paper
- Single-hole punch
- Yarn, twill string
- Scissors
- Paper clips
- Copies of the "praying hands," four per student

#### Preparation

Before class, write the word "PRAY" in large bubble letters on four sheets of construction paper. Then, cut the letters out and, using a hole punch, punch a single hole at the bottom of each letter. Lastly, cut four pieces of yarn or twill, each around a foot long. Braid one piece at the bottom of each letter.

#### Instructions

1. Quiz the students on the reasons why we need to pray.
2. Write the letters "PRAY" in the form of an acrostic poem (i.e., begin each line with a letter from the word "PRAY," spelling out the word vertically) on the board. Using the first letter in each line, spell out "Praise," "Repent," "Ask," and "Yield." Then, explain the significance of each step and why they should all be included in prayer.
3. Distribute four copies of the "praying hands" to each student, and show them the letters that you prepared before class. Explain to them that they will be writing down events that apply to each category of prayer and attaching the hands to the strings.

Praise  
Repent  
ASK  
Yield

For each of the four "categories" of prayer, the students must write a specific event that would require them to make this particular kind of prayer. Examples have been provided.

PRAISE God for healing my grandma of an illness.  
 REPENT to God for speaking foul language.  
 ASK God to give me wisdom when studying.  
 YIELD to God and accept whichever school into which I'm admitted.

4. When the students have finished writing on the hands, use the paper clips to help attach them to the braids dangling from each letter.
5. Hang the "praying hands" somewhere in class where everyone can see them. This will remind students to pray for one another. Leave extra "praying hands" nearby so students can update their prayers.

## 2. In My Own Words

**Objective:** To put the Lord's Prayer into practice and remind students how they should pray.

#### Materials

- Activity handout
- Hymn books

#### Instructions

1. On the activity handout, ask students to write out the first half of the Lord's Prayer (Mt 6:9-11) in the first box.
2. Under each teaching in the second box, students must write a list of relevant prayer requests that they currently have. Emphasize that this is for their personal prayers, so it will be most beneficial to them if they are honest. The more specific, the better it will help their prayers.
3. Tell students to post this worksheet on their bedroom wall somewhere visible so that before they pray, they are reminded of what they can specifically pray for and how they can pray.
4. Choose several prayerful hymns (e.g., "Pentecostal Power," "Tell It to Jesus," "Did You Think to Pray," etc.) and sing these with the students.
5. Remind the students that they can also sing these hymns in their hearts during prayers to remember the manner in which they should pray.



**THE LORD'S PRAYER (PART 1)**

Write the Lord's Prayer below and highlight the main words of each line.



Summary	Bible Verses
<p><i>Our Father in heaven,</i></p> <ul style="list-style-type: none"> <li>•</li> <li>•</li> <li>•</li> </ul>	
<p><i>Hallowed be Your name.</i></p> <ul style="list-style-type: none"> <li>•</li> <li>•</li> </ul>	
<p><i>Your kingdom come. Your will be done on earth as it is in heaven.</i></p> <ul style="list-style-type: none"> <li>•</li> <li>•</li> </ul>	
<p><i>Give us this day our daily bread.</i></p> <ul style="list-style-type: none"> <li>•</li> <li>•</li> </ul>	

**Bible Detectives**

Compare the two passages below and circle parts that are the same and underline what you think is different.

<p>"For your Father knows the things you have need of before you ask Him. In this manner, therefore, pray:</p> <p style="text-align: center;">Our Father in heaven, Hallowed be Your name. Your kingdom come, Your will be done On earth as it is in heaven. Give us this day our daily bread."</p> <p style="text-align: center;">(Matthew 6:8-11)</p>	<p>"'Lord, teach us to pray, as John also taught his disciples.' So He said to them, 'When you pray, say:</p> <p style="text-align: center;">Our Father in heaven, Hallowed be Your name. Your kingdom come. Your will be done On earth as it is in heaven. Give us day by day day our daily bread.'" </p> <p style="text-align: center;">(Luke 11:1-3)</p>
---	---

### A Father and His Children

**“In the name of Jesus, I pray...”**

Write a prayer in your own words to God, making sure to include all the teachings you have learned from the Lord's Prayer.

Our Father in heaven,  Hallowed be Your name.  Your kingdom come.  Your will be done on earth as it is in heaven.  Give us this day our daily bread.	Amen.
--	-------





**In My Own Words**

Referring to Matthew 6:9-11, write the first half of the Lord's Prayer below.

Our Father in heaven,

Hallowed be Your name.

Your kingdom come. Your will be done on earth as it is in heaven.

Give us this day our daily bread.



E2 Year 2 Book 2 Lesson 5—The Lord's Prayer (Part 1)

# Homework Assignment

Name: \_\_\_\_\_ Parent signature: \_\_\_\_\_ Date: \_\_\_\_\_

Weekly Bible Reading: \_\_\_\_\_

**Bible Reading:** Check each box when you complete that day's reading.

**Prayer:** Check each box after you pray to God that day.

	Sun	Mon	Tue	Wed	Thu	Fri	Sat
Read							
Pray							

## What I Learned from the Bible This Week

1. \_\_\_\_\_  
 \_\_\_\_\_  
 \_\_\_\_\_
2. \_\_\_\_\_  
 \_\_\_\_\_  
 \_\_\_\_\_

## Memory Verse

Please write down this week's memory verse. **(Philippians 4:6)**

\_\_\_\_\_

### Putting the Lord's Prayer into Practice

Either at church or at home, ask brothers, sisters, parents, siblings, or relatives to give you a testimony of one time when they made a prayer from one of the four categories listed below. Write down the main points of their testimony and what you learned from it.

Seeking God's care and love as a heavenly Father...

*Our Father in heaven.*

Asking God for His power to change a weakness in their lives...

*Hallowed be Your name.*

Understanding God's plan for a specific part of their life....

*Your kingdom come. Your will be done on earth as it is in heaven.*

Thanking God for providing something in their life...

*Give us this day our daily bread.*

# LESSON 6

## THE LORD'S PRAYER (PART 2)

### OBJECTIVES

1. To understand that we must forgive others because God forgives us.
2. To develop faith that God will protect and deliver us from evil.
3. To know that God is in control and has power over everything.

### MEMORY VERSE

"For if you forgive men their trespasses, your heavenly Father will also forgive you. But if you do not forgive men their trespasses, neither will your Father forgive your trespasses."

(Matthew 6:14-15)

### PRAYER

Prior to the prayer, remind the students that prayers are opportunities to:

1. Praise God's name,
2. Build a relationship with Him,
3. Think about what God has in plan for us, and
4. Request for our needs as well as the needs of others.

Tell the students to put these four teachings into practice during their opening prayer.



### Overview

#### 1. The Lord's Prayer: Part 2 (Mt 6:12-15; Lk 11:4-13)

- God forgives: "And forgive us our debts, as we forgive our debtors." (Mt 18:21-35; 1 Jn 1:8-10; Mt 5:24-25)
- God helps and protects: "And do not lead us into temptation, but deliver us from the evil one." (Jas 1:12-15; 1 Cor 10:11-13; 2 Tim 2:22-26)
- God is in control: "For Yours is the kingdom and the power and the glory forever. Amen." (Rev 1:6; Heb 12:22-24, 28-29)

#### 2. Linking to the Ten Basic Beliefs

Our God is the one true God, so He has all the power and glory. He can help us and protect us in all circumstances.

#### 3. Life Application

- Forgiveness
- How God Will Help Me

#### 4. Activity

- In Thought, in Speech, in Conduct
- A Prayer for My RE Class



### Background Knowledge for Teachers

#### Dealing with Debt, Sin, and Trespasses

From Matthew 6:12 onwards, there is a shift in the focus of the Lord's Prayer. The first five lines focused on God alone, and the next on our physical need. However, the final five lines of the Lord's Prayer, and Jesus' words immediately after the prayer, are focused around the concept of debt, sin, and trespasses to depict the essence of man's relationship with God through prayer. Though these terms may sound similar, their subtle differences illustrate the progression of a Christian's entire relationship with God. Debts and debtors imply an obligation towards another, a debt that we owe. Sin (literally: "to miss a mark") is used in contrast to debt in Luke 11:4, comparing our sins that need to be forgiven with our forgiveness of others' debts toward us. Lastly, trespasses as mentioned in Matthew 6:14 refers to one's failures, mistakes, or slips in error that we must forgive (cf. Col 2:13-14). Where the first half of the Lord's Prayer depicts God's relationship with us, the final half of the Lord's Prayer shows our relationship with Him.



- Debtors: We are eternally indebted to the higher and greater God.
- Sin/temptation: We face the temptation to be ensnared and fall to sin in this world.
- Trespasses: When we fall and slip, we once again seek God's righteous mercy.

Jesus' message was that this entire message of Christian life had to be explored and experienced in prayer, from reflection to repentance to renewal.



## Reaching Out to Your Students

### "I'm Sorry"

Many students are used to saying "I'm sorry" or making excuses when they do something wrong. When God seeks a closer relationship with His children, He first requires that they be holy, for He is holy. Remind your students that repentance in prayer is vital to having a healthy prayer relationship with God and that this repentance must extend to their actions outside of prayer.

### The Life Jacket

We also need to train students in understanding that prayers shouldn't be treated as life jackets. We cannot recite the Lord's Prayer only when we think it is necessary. The content of the Lord's Prayer taught the disciples how to pray every day. Unlike a life jacket that gathers dust in the wardrobe for emergencies, prayer is the one thing we need to carry around with us every day. Constant prayer will help us forge a strong relationship with our Father.



## Opener

5 Minutes

What goes through your mind when you are praying? Do you think about playing with your friends, what you will do after church, or how long the prayer will last for? Or are you thinking about a person you need to pray for, about the things you've done wrong in the past week, or how God has helped you in the past week?

### For Teachers

1. Give a short testimony of when you have drifted in your thoughts while praying, even though you were praying physically.
2. Provide the students each with a small piece of paper and ask them to list out five things they think about while they are praying. Note: It is important to keep this instruction open-ended so that the students have the opportunity to list both spiritual and secular thoughts. When they are done, collect the pieces of paper.
3. Divide the board into two sections. On one side, list out the secular thoughts that were written, including your own. Creative license can be used when illustrating this activity (e.g., mind maps around a brain, a praying figurine, different colors, etc.).
4. Now, ask the students what kind of thoughts they can think about during prayer based on last week's lesson on the Lord's Prayer and list these out on the other side. Examples may be thinking of God as their Father, thinking about what they need, thinking of how God has guided them, etc.

God doesn't want us to have an empty mind when we are praying to Him. He wants our mind to be full of thoughts, but these thoughts must be ones that are pleasing to God. Sometimes, this means thinking about things we've done wrong or things we're ashamed of. We can't hide anything from God, and this week in the second half of the Lord's Prayer, we will learn just how important it is to think and reflect while we pray.



## Vocabulary

**temptation:** something that lures you to sin

**debtor:** someone who owes something to someone else

**trespasses:** when someone crosses a line and does wrong

**resolve:** the determination to do something; the strong aim and goal to do something

**amen:** truly



## Bible Discovery & Spiritual Teaching

30-35 Minutes

### FOR TEACHERS

Please hand out the Bible Discovery worksheet and ask the students to fill it out as the lesson progresses. Instruct students to write down the summarized bullet points at the end of each section. Keep a copy for yourself as reference.

Let us read the Lord's Prayer together in **Matthew 6:9-13**.

On your worksheets, underline with a pencil the main words for this part of the Lord's Prayer. Now, please highlight the following words. [On the board, write: "forgive, debts, forgive, debtors, temptation, deliver, evil one, kingdom, power, glory."]

**"And forgive us our debts, as we forgive our debtors."**

Students, who knows what a debt is or who a debtor is? For example, if I were to borrow \$5 from you, then I would owe you a debt of \$5 and I would be your debtor. Talk to your classmate next to you and think of another example of a debt. Debts aren't only physical things. We can hold emotional debts as well. If your brother or sister broke your favorite game or ripped your favorite article of clothing, you would want your parents to replace it for you. But what would you expect from your brother or sister? Would you expect them to be nicer to you, to be kind and help you with other things as compensation? If you would, you are holding them as an emotional debtor.

Let us turn to **Matthew 18:21-35**. The debt that the servant owed the master was 10,000 talents (v. 24). One talent equaled 6,000 days of wages. So, how many days would you have to work to earn 10,000 talents? You would have to work 60,000,000 days, or if you worked from you were first born, 164,384 years. Now how much did the second servant owe the first servant? 100 denarii. This equals 100 days of working. Is this still a lot of money? Yes it is—but compared to what the first servant owed the master, it was nothing! Students, our master today is God; we are the first servant that owed all the money and the second servant that owed the first servant are all our brothers, sisters, family, and friends around us. Even though they may do things that may hurt us and

make us angry, we must remember how often we have sinned against God and how unworthy we are.

### FOR TEACHERS

Ask students to fill in the definitions for "debt" and "forgiveness," and then turn to page 2 and answer the questions about the parable. The answers for the parable have been provided here.

#### Answers

- a. 10,000 talents. b. 60 million days of working. c. Sell himself, his wife, his children, and all that he had.
- a. 100 denarii. b. 100 days of working. c. Tortured until he paid all that was due to the king.
- a. My life; He died to save me and forgave my sins. b. No. c. Answers may vary.

So, when we pray to God, like in the Lord's Prayer, we must examine ourselves and see if there are grudges we hold against someone else. In the Lord's Prayer, what action must come first? Do we ask for God to forgive our debts first, or do we forgive others' debts to us first? Let us turn to **Matthew 5:23-24**. When we worship God and pray to God, we need to think of whether there are people that we still haven't forgiven. If there are, then we must forgive them—in person and in our hearts. After we have done that, we can ask God to forgive us because what we owe God is far greater than what anyone could owe us (1 Jn 1:8-10).

#### Summary

- What we owe God is more than what anyone could ever owe us.
- We need to forgive others before we can ask God to forgive us.

**"And do not lead us into temptation, but deliver us from the evil one."**

Let us read the next two lines in **Matthew 6:13** again.

What does it mean to be led into temptation? Boys and girls, let us do a secret survey. Everyone put your heads down. Now, raise your hands if you've ever done something your parents told you specifically not to do.

Keep your hands up if the thing you did felt fun or good at the time you were doing it. Now, keep your hands up if you felt guilty or wanted to hide this thing you had done from your parents afterwards. Okay, everyone can put your hands down and raise your head up now.

Temptation occurs when we are led to do something wrong. What are we led by? By God? No; we are led by our own desires, by our heart, by bad people around us, and by Satan, who is trying to make us fall (Jas 1:12-15)! These things are called temptations because even though we know they are wrong, we still want to do them. Let us turn to **1 Corinthians 10:11-13**. We need to first know that to yield to temptations is wrong! "No temptation has overtaken you except such as is common to man; but God is faithful." Students, let us take special note of this statement: "But God is faithful." This is a promise from God! He will help us, but only if we put in the strength and resolve to rely on Him. Where do we get this strength from God? (Prayers.) That is right—through prayer.

We also need to ask God to deliver us from the evil one. We are completely vulnerable unless we seek God and rely on His protection all the time. God is our shield and unfailing help (Ps 28:7).

What are the temptations around us? A lot of temptations are hidden behind the computer screen. What about video games? Friends who are a bad influence? Our need to gossip? Our minds, our eyes, our ears, our hands...we must be careful how we use them. We should think about all of this in prayer and be ready to resist temptations after prayer. Let us turn to **2 Timothy 2:22-26**. The most important thing to remember about our prayers is that we must act out whatever goodwill we think and pray to God about during our prayers.

### Summary

- We are tempted by things around us because of our own desires.
- We must think of our weaknesses in prayer, resolve to get rid of them, and put our resolutions into action afterwards.
- This may sometimes mean avoiding things we may like or have a desire for.

**"For Yours is the kingdom and the power and the glory forever. Amen."**

Now, what is the last line of the Lord's Prayer? Let's say it together without looking at our Bible or our worksheets! "For Yours is the kingdom and the power and the glory forever. Amen."

Raise your hands if you have sung "The Lord's Prayer" in our hymn book before. [If class time and pianist availability permit, teachers are encouraged to sing it with the students.] Let us look at the hymn now. Who knows which part of the hymn is the highest and loudest? Is it the beginning? The middle? No, it is the end—when we are praising God's kingdom. This is the greatest part of The Lord's Prayer. We are a part of this kingdom today! Let us read **Revelation 1:6**. God has made us His children, and kings and priests! This means that God has given us His power to forgive others, to overcome temptation, and to be delivered from the evil one. Furthermore, we are also safe in His kingdom. Imagine being in a physical castle so strong, with walls so tall that no matter the arrows or bombs that are shot, they cannot penetrate the wall. No spies can sneak in, and we are completely safe. This is what it is like spiritually to be baptised into the blood of Jesus today! Let us turn to **Hebrews 12:22-24, 28-29**. How does the author describe the kingdom of God? It "cannot be shaken." In other words, it is unshakeable. Let us say that together with a loud, strong voice. "Unshakeable!"

Only God can make our prayers possible, and He controls everything (Lk 1:37). So, when we pray to forgive others, to overcome the things that tempt us, and to deliver us, we need to remember that we are in God's kingdom. We must also remember that He will keep us safe and that through His power, He listens to and makes our prayers possible. Therefore, let us not forget to give the glory to Him for any success in any area. The last word we say in the Lord's Prayer is so important. "Amen." Meaning "truly," it represents that you will leave everything you have prayed for in God's hands and allow Him to work.

### Summary

- We belong to God's kingdom, and He keeps us safe.
- Everything for which we pray is in His control and made possible by His power.

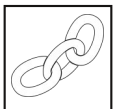

## Linking to the Ten Basic Beliefs

2-5 Minutes

### One true God

Our heavenly Father to whom we pray is the one true God. Omniscient, omnipresent, and omnipotent, He is the one who created the heavens and the earth. So, He has all the power and glory. He can help us and protect us in all circumstances.



## Check for Understanding

5 Minutes

So, now let us do a quick review of the teachings from each part of the Lord's Prayer. What does each of the following lines teach us?

- "Our Father in heaven." We have a relationship with a heavenly Father.
- "Hallowed be Your name." God's name is holy, and we must praise His name.
- "Your will be done." Everything is done with a purpose in our lives.
- "Give us this day our daily bread." God will look after our needs.
- "And forgive us our debts." We owe God, and we must forgive others first.
- "And do not lead us into temptation, but deliver us from the evil one." We must flee from what tempts us and rely on the power of the Holy Spirit.
- "For yours is the kingdom and the power and the glory forever." We are safe in God's kingdom.

1. **Give an example of a debt we may hold against others.** Physical debt: broken toys or video games; emotional debt: how they treat us or the way we see them.
2. **What debt do we owe God?** The sins that we committed for which He died on the cross.
3. **What is a temptation?** Something that we know is wrong, but still want to do.
4. **How can we be delivered from temptation?** We can pray to God and rely on Him to help us find "the way out."
5. **What kind of kingdom is God's kingdom?** It is a spiritual one where we are baptised in Jesus' blood.
6. **What will His kingdom, power, and glory protect us from?** The devil's attempts to lure us into temptation. [Provide real examples and ask students if they have their own.]



## Life Application

10 Minutes

### 1. Forgiveness

#### "Us" and "We" – United and Intercessory Prayers

The Lord's Prayer wasn't written with singular pronouns ("I", "me") but with collective pronouns ("Us", "we"). On one hand, this was because Jesus was addressing all His disciples, but, on the other hand, it also teaches us the need to share our weaknesses with one another and intercede in the matters of forgiveness and overcoming temptation. Students have been taught to pray for others when they are sick or in trouble, but the Book of James tells us the best way for us to effectively pray for one another (Jas 5:16).

#### "As we forgive our debtors..." – Putting Our Prayer Requests Into Action

Our relationship with God is directly influenced by our relationship with those around us. If we cannot love our brothers whom we can see, how can we love God whom we have not seen? (1 Jn 4:20). Ask the students how they show their love to God. All their answers, if appropriate, should fall under the banner of this statement: "We love the things that God loves." If we want to say that we love God, then we need to show God how we love Him. The same goes for asking for forgiveness from God, or asking God to deliver us from the evil one. Everything we say in prayer must be lived out in our thoughts, speech, and conduct.

[Refer to Life Application Worksheet #1 to sum up the two primary life application teachings.]

We need forgiveness from God, but we first need to show forgiveness to others.

For each of columns (at school, at church, and at home), the students will write about someone they've been angry with before. They must write what that person did, why the student was angry with them, and what the debt was that the person owed the student. In the last column, the students will write about one specific debt they owe to God (i.e., one thing they've done wrong). [The teacher may choose to post the worksheets on the wall so students can pray for one another, or the students can just take the worksheet home and post it on their bedroom wall. If there is sufficient class time, the teacher can refer to these following verses as a follow-up: Psalm 130:3-4, Psalm 51:10-11, and 1 John 1:9-10.]



## 2. How God Will Help Me

[Hand out Life Application Worksheet #2 and ask the students to complete it. When they have finished, go over the worksheet as a class.]

God will always listen to our prayers, but we need to know when we need His help and do our best to seek Him when we are in trouble!

In the following situations, match the student's trouble with a relevant Bible verse. Then, below it, tell them how God will help them by writing one of the four teachings:

1. God forgives me and I must forgive others.
2. God will help me to do what is right.
3. God will protect me from evil.
4. God is in control, and He has the power.

### Answers

1. 1 John 4:3-4; God will protect me from evil.
2. 1 John 4:19-20/Colossians 3:13; God forgives me and I must forgive others.
3. 1 John 4:19-20/Colossians 3:13; God forgives me and I must forgive others.
4. Psalm 91:11-12; God is in control and He has the power.
5. Acts 20:33; God will help me to do what is right.
6. Psalm 91:11-12; God is in control and He has the power.
7. Psalm 42:11; God will protect me from evil.
8. Proverbs 11:1; God will help me to do what is right.



## Activity

### 1. In Thought, In Speech, In Conduct / 2. A Prayer for My RE Class

10-15 Minutes

#### 1. In Thought, In Speech, In Conduct

**Objectives:** 1. To remind the students that they can pray together.  
2. To remind the students that prayer must come from our mouth, our conduct, and our thoughts.

#### Materials

- Activity cut-outs [Note: Print out multiple pairs of feet per student, up to 10 footprints may be used.]
- Markers
- Blu-Tack or tape

#### Instructions

1. Distribute one set of cut-outs per student, giving each student at least 6 footprint cut-outs.
2. Ask the students to think of one area they need to improve in. Write this on the back of their heart. Remind the students of the importance of prayers and intercession in accomplishing things.
3. Instruct them to write the following on the front of their heart:

1. Their name
2. Psalm 119:11 (verse and reference)
3. "Hallelujah!"

4. On the footprints, they are to write the practical steps they will take to achieve this spiritual goal. Each footprint should be one step.
5. In the speech bubble, the students must write the actual prayer they will say to God. →
6. Post these around the classroom walls as a step-by-step trail that the students can see and follow: Speech Bubble  
Footprints      Heart.

## 2. A Prayer for My RE Class

**Objective:** To remind students that the Lord's Prayer is also applicable in praying for the entire church and class.

1. Upon completion of the Check for Understanding section, write the main teaching for each line of the Lord's Prayer on the board.
2. Remind students that even though we can pray for ourselves in all of these areas very easily, the church and the class as a whole also need our prayers. Emphasize how the Lord's Prayer uses "us" and "we."
3. Ask the students to each write a prayer in the perspective of the RE class. Write a point for each line of the Lord's Prayer, focusing on:
  - a. What are the church's physical needs?
  - b. Do classmates ever argue with each other during class?
  - c. From what does the class need protection?
  - d. How can the class work together to be united in the kingdom and in God's power?
4. Ask some students to share the prayer they have written for the class.

[Note: This activity can also be in the form of a letter or a poem.]





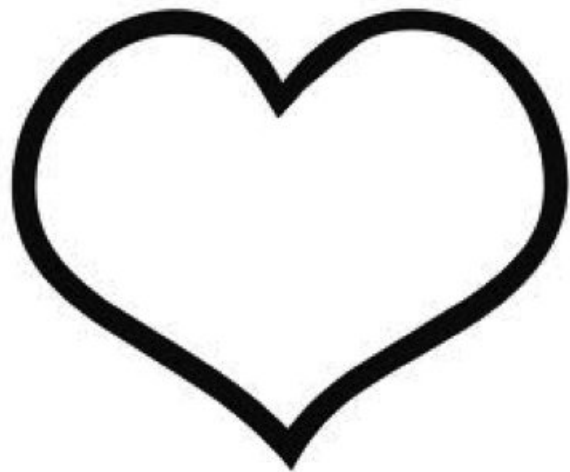
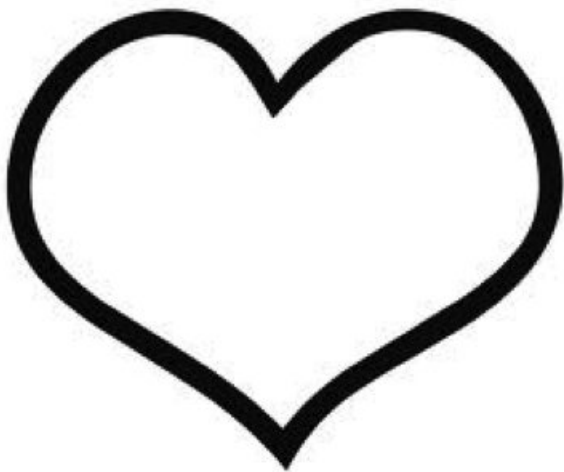
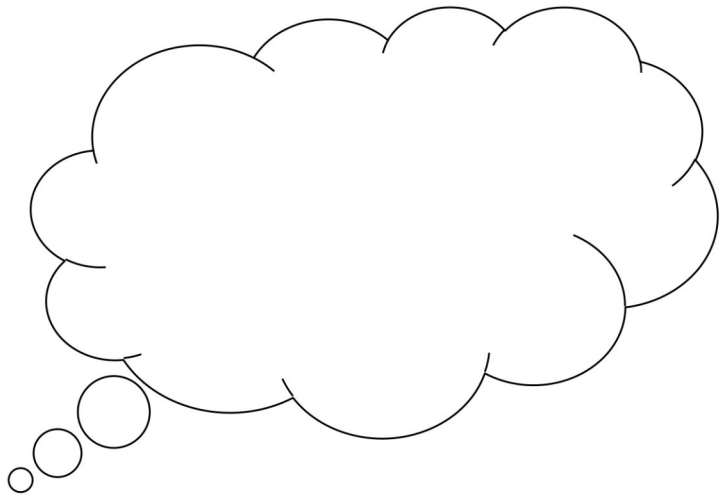
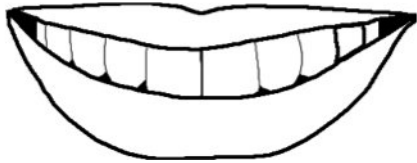
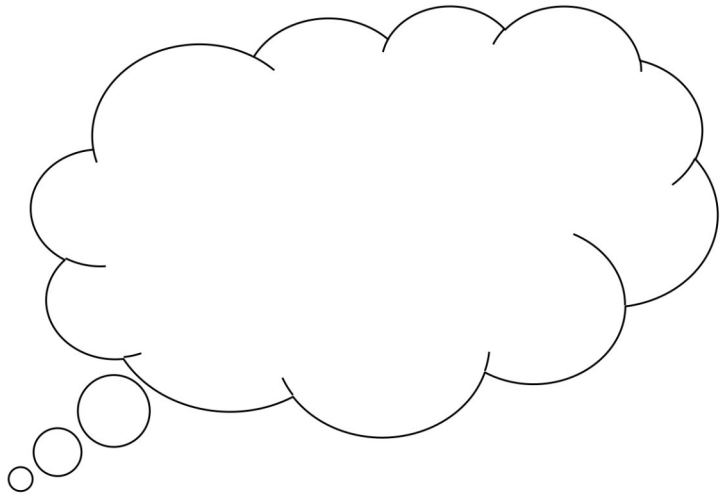
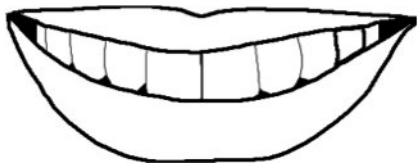



**THE LORD'S PRAYER (PART 2)**

*And forgive us our debts,  
As we forgive our debtors.  
And do not lead us into temptation,  
But deliver us from the evil one.*

*For Yours is the kingdom and the power and the glory forever.*

*Amen.*

Summary	Bible Verses
<p><i>And forgive us our debts, as we forgive our debtors.</i></p> <ul style="list-style-type: none"> <li>•</li> <li>•</li> </ul>	
<p><i>And do not lead us into temptation, but deliver us from the evil one.</i></p> <ul style="list-style-type: none"> <li>•</li> <li>•</li> <li>•</li> </ul>	
<p><i>For Yours is the kingdom and the power and the glory forever. Amen.</i></p> <ul style="list-style-type: none"> <li>•</li> <li>•</li> </ul>	

**Bible Professors**

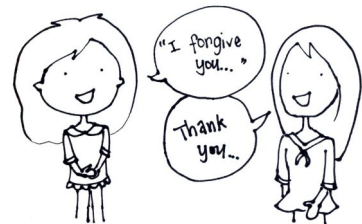

Please write the definition for the following words.

<p>Debt</p>	<p>Forgiveness</p>
-------------	--------------------

**Bible Diggers**

*Who is the debtor? Who needs forgiveness?*

**Matthew 18:21-35**

## 1. The king and the servant

- a. How much did the servant owe the king?
  
  
  
  
  
  
  
  
  
  
- b. How much is that in today's terms?
  
  
  
  
  
  
  
  
  
  
- c. How was the servant going to have to pay back the king?

## 2. The servant and his fellow servant

- a. How much did his fellow servant owe him?
  
  
  
  
  
  
  
  
  
  
- b. How much is that in today's terms?
  
  
  
  
  
  
  
  
  
  
- c. How did the king punish the servant for his lack of forgiveness?

## 3. God and I

- a. What do I owe God today?
  
  
  
  
  
  
  
  
  
  
- b. Can I ever repay Him?
  
  
  
  
  
  
  
  
  
  
- c. Name some examples of people I have to forgive.

### Forgiveness

"As we forgive our debtors..."



At School	At Church	At Home	In my heart...

*I forgive my debtors... help pray for me that God may forgive me.*

### How God Will Help Me



God will always listen to our prayers, but we need to know when we need His help and do our best to seek Him when we are in trouble!

In the following situations, match the student's trouble with a relevant Bible verse. Then, below it, tell them how God will help them by writing one of the four teachings:





1. God forgives me and I must forgive others.
2. God will help me to do what is right.
3. God will protect me from evil.
4. God is in control, and He has the power.

**Bible Verses**

- 1 John 4:19-20
- Acts 20:33
- Psalm 42:11
- 1 John 4:3-4
- Proverbs 11:1
- Psalm 91:11-12
- Colossians 3:13

Scenario	Bible Verse
<p>Jim heard some ghost stories from his friends at school. He was worried about being in the dark, thinking that Satan and his demons would harm him. So, he prayed to God and memorized a verse about God's prayer to recite when he was scared.</p> <p><b>Teaching:</b></p>	
<div style="display: flex; align-items: center;">  <div style="margin-left: 20px;"> <p>Judy's younger sister tore the sleeve of her favorite dress when trying it on. Judy was furious with her sister. She prayed to God until her heart calmed down and remembered that loving her sister was more important than the dress.</p> <p><b>Teaching:</b></p> </div> </div>	
<p>Sean's mom was very late when picking him up from school, causing him to miss soccer practice. Sean didn't want to even look at his mom. Then, he remembered all the other times his mom had come early, even bringing a snack for him to eat before practice. Sean prayed to God to forgive him and thanked his mom for picking him up even though she was so busy.</p> <p><b>Teaching:</b></p>	

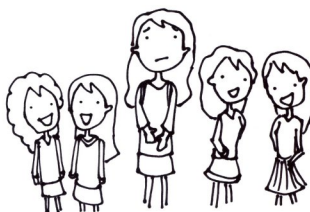

Scenario	Bible Verse
 <p>Tracy's family was driving down a busy, icy road one cold night when a truck zoomed past and bumped into their car. Their car started to spin out of control. Not knowing what else to do, Tracy's whole family screamed, "Hallelujah!" and their car stopped at the side of the road without hitting any other cars.</p> <p><b>Teaching:</b></p>	
<p>Jason found a \$50 bill on the ground at school. There was a new game that he really wanted that cost the same price. But Jason knew that this wasn't his money. He prayed to God to help him overcome this desire and handed the money to his teacher.</p> <p><b>Teaching:</b></p>	
 <p>Harry's dad lost his job. So, Harry and his parents prayed every day that God would help his dad find another job. Thankfully, his dad found a job that was even better than the last one!</p> <p><b>Teaching:</b></p>	
<p>Carrie was awkwardly taller than the other girls at school. They often made fun of her and called her names. She always felt sad until her RE teacher encouraged her to pray to God every time she felt hurt by the words and to remember hymns that would cheer her up so the evil teasing wouldn't hurt her. Eventually, the words didn't hurt her anymore, so the other students got bored and stopped calling her names. This is one way we, as children of God, can be free from verbal bullying.</p> <p><b>Teaching:</b></p>	
 <p>Jamie's friends wanted to share answers to the test. But Jamie didn't want to cheat, so she prayed to God to give her the courage to be honest. With God's help, she was able to refuse to share her answers.</p> <p><b>Teaching:</b></p>	

E2 Year 2 Book 2 Lesson 6—The Lord's Prayer (Part 2)

# Homework Assignment

Name: \_\_\_\_\_ Parent signature: \_\_\_\_\_ Date: \_\_\_\_\_

Weekly Bible Reading: \_\_\_\_\_

**Bible Reading:** Check each box when you complete that day's reading.

**Prayer:** Check each box after you pray to God that day.

	Sun	Mon	Tue	Wed	Thu	Fri	Sat
Read							
Pray							

## What I Learned from the Bible This Week

1. \_\_\_\_\_  
 \_\_\_\_\_  
 \_\_\_\_\_
2. \_\_\_\_\_  
 \_\_\_\_\_  
 \_\_\_\_\_

## Memory Verse

Please write down this week's memory verse. **(Matthew 6:14-15)**

\_\_\_\_\_

### The Lord's Prayer – from the Bible

Think of one Bible character that lived a life as illustrated in the phrase. (E.g., "Give us this day our daily bread" – The widow from Zarephath and Elijah.) Answer the following questions for each of them:

1. What is/was their name(s)?
2. How did they live out this line of the Lord's Prayer?
3. How can I imitate their lives today? (Be specific!)

"Forgive us our debts, as we forgive our debtors."

- 1.
- 2.
- 3.

"Do not lead us into temptation."

- 1.
- 2.
- 3.

"But deliver us from the evil one."

- 1.
- 2.
- 3.

"For Yours is the kingdom and the power and the glory forever. Amen."

- 1.
- 2.
- 3.

### Tackling Temptation

Think of what Jesus would want you to do in each of these scenarios. Answer how God can give you the strength to tackle and overcome this temptation!

1. Sometimes, I am tempted to copy someone else's homework answers.

*God can give me strength to...*

2. Sometimes, I am tempted to pretend I'm sick to stay home from church and play games.

*God can give me strength to...*



3. Sometimes, I am tempted to take a candy bar even though my parents said, "No."

*God can give me strength to...*

4. Sometimes, I am tempted to make fun of someone in school who is different.

*God can give me strength to...*



5. Sometimes, I am tempted to use bad language when I'm angry.

*God can give me strength to...*

6. Sometimes, I am tempted to blame my siblings when I get into trouble with my parents.

*God can give me strength to...*

7. Sometimes, I am tempted to laugh when someone is being teased.

*God can give me strength to...*



8. Sometimes, I am tempted to watch a TV show Mom said not to watch.

*God can give me strength to...*

9. Sometimes, I am tempted to hide my toys and dirty laundry under my bed when Dad says to clean up.

*God can give me strength to...*

10. Sometimes, I am tempted to be rude to my teacher or church members.

*God can give me strength to...*

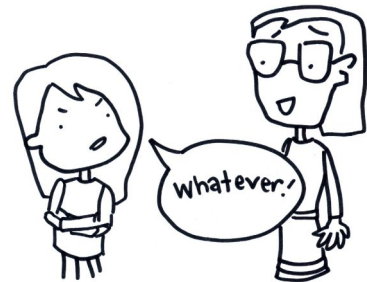

11. Sometimes, I am tempted to lie to my RE teachers and say I've forgotten my workbook when I didn't do my homework.

*God can give me strength to...*

12. Sometimes, I am tempted to tell my parents I need the computer to do my assignment when I'm really playing Internet games.

*God can give me strength to...*



# LESSON 7

## FOUR GREAT PRAYERS IN THE OLD TESTAMENT

### OBJECTIVES

1. To find God's mercy in prayer during conflicts with others.
2. To discover God's comfort in prayer during trials.
3. To receive God's blessing in prayer during times of need.
4. To ask for God's wisdom when making decisions.

### MEMORY VERSE

"Now this is the confidence that we have in Him, that if we ask anything according to His will, He hears us."

(1 John 5:14)

### PRAYER

1. Thank God for guiding and protecting us this week so that we can come to Him in Spirit and in truth.
2. Praise God for the prayers He has answered, those He has chosen to delay, and the ones He has turned away.
3. Ask God for the wisdom to seek Him through prayer in times of joy or sadness, victory or failure.



### Overview

1. **Jacob's prayer for mercy from Esau (Gen 32:3-12)**
2. **Moses' prayer in affliction (Num 11:4-25)**
3. **Hannah's prayer for a son (1 Sam 1-2:11)**
4. **Solomon's prayer for wisdom (1 Kgs 3:4-15)**
5. **Linking to the Ten Basic Beliefs**

- Jesus Christ, our God, hears and knows the prayers we offer today.
- The Holy Bible includes testimonies on the effectiveness of prayer.
- The Holy Spirit takes our prayers to God and delivers God's providence and guidance.

6. **Life Application**—Prayer Works; Keeping Up with Prayer
  - We can pray in any and every circumstance.
  - Prayer makes the impossible, possible.



### Background Knowledge for Teachers

#### A Bowl of Soup for a Birthright

According to the Talmud, the sale of Esau's birthright took place immediately after Abraham died. The Talmudic dating estimated Esau and Jacob to be around 15 at the time. It is also suggested that the death of Abraham on the same day was appropriate so that he would not witness the demise of his grandson Esau. The lentils Jacob had cooked were meant for his father Isaac because lentils are the traditional meal for Jewish people in mourning.

#### Barrenness to Birth

In biblical times, women did not have equal status with men. Women were considered the property of their fathers or husbands. Women held subservient roles. A woman couldn't leave her husband because he owned her, just like he owned sheep or goats. Generally, Israelite women fared much better than women in other cultures around them. This was by the mercy of God.

Giving birth gave women a considerable increase in status. Their position was literally saved through childbirth. Unfortunately, however, a barren woman was considered disgraced and cursed by God.

The average Israelite woman nursed her child for two to three years while running the household and caring for her older children. At age three, boys were placed under their father's tutelage and taught from the Torah once it was written. Education was forbidden for girls and women.

Jewish women were given privilege and respect according to the number of sons they bore. This was due to the fact that it was only the sons who remained with the family and increased in wealth. Only sons inherited property and provided for elderly parents.

Sons were definitely the preferred gender, but daughters were not shunned. Daughters in Israel had better standing than in the surrounding pagan cultures. In some cultures, newborn girls were left on mountains to die or given as child sacrifices to false gods.

In Israel, mothers taught their daughters. Girls only learned skills that would make them good wives, essential for when they reached the marrying age of twelve and a half. The Talmud stated that a good wife was the only kind to keep. The Torah viewed a bad wife as bad as leprosy to her husband.



## Reaching Out to Your Students

Students may have grown accustomed to hearing that they need to pray and read the Bible to cultivate their spiritual lives. Over time, this phrase might feel like an unattainable slogan instead of an undeniable truth. By studying the circumstances and results of four important prayers in the Old Testament, students can become re-sensitized to the wonders and effectiveness of sharing their hearts with God and trusting Him to provide and lead the way. The same God who listened and granted prayers thousands of years ago is the same God that resides in their hearts and cares for them today.



## Opener

*5 Minutes*

Prayer is like breathing. We might not actively think about it, but if we stop doing it, we will not live. The Bible records all different types of prayers to God. Jacob prayed for mercy from his twin brother Esau. Moses prayed during his trial dealing with countless complaining Israelites. Hannah prayed for a son to dedicate to the Lord. Solomon prayed for wisdom to judge over the people of God. Today, we will learn from these four different prayers so that we can make prayer, like breathing, an indispensable part of our daily lives.

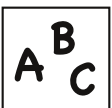

## Vocabulary

- bosom:** chest; somewhere close to one's heart
- consecrate:** to sanctify, make holy
- despise:** to hate, not appreciate, look down upon
- anguish:** extreme pain or sadness; grief
- conceive:** to become pregnant
- wean:** to stop feeding a baby his/her mother's milk
- ephah:** a measure for grain (equivalent to 36.4 liters)
- feeble:** weak





## Bible Discovery & Spiritual Teaching

30-35 Minutes

### FOR TEACHERS

Distribute Bible Discovery Worksheet #1 to the students now. The students will be referring to it throughout the lesson and filling in the blanks. The answers have been bolded in this section.

### Jacob's prayer for mercy from Esau (Gen 32:3-12)

After taking his older brother's birthright in exchange for a bowl of soup, Jacob prepared to meet his twin brother Esau following many years of living far away. He sent messengers ahead to announce his arrival to Esau and ask for his favor.

The messengers returned to Jacob, saying, "We went to your brother Esau. He is coming to meet you with four hundred men." When he heard this, Jacob was greatly afraid and distressed. Why do you think he was scared? Yes, it was because Jacob thought that his brother was still angry with him for taking his birthright. He thought Esau might come to attack him and his family as revenge.

Jacob divided his people, flocks, herds, and camels into two companies. He thought, "If Esau attacks the first company, then the second company can escape." What would you do if you were in Jacob's shoes? You might try to hide, run away, or go around Esau's camp, right?

There was no one that could help Jacob. His only and best option was to turn to God, who had always watched over him faithfully. Jacob prayed, "Oh God of Abraham and Isaac, the Lord who said to me, 'Return to your country and to your family, and I will deal well with you.' I am not worthy of the least of all the **mercies** and of all the truth which You have shown Your servant. When I first crossed over this Jordan River, I only had my staff, and now I have become two companies of people and animals. **Deliver** me, I pray, from the hand of my brother Esau. I fear him because he might come and attack my wives, my children, and me. You said, 'I will surely treat you well, and make your descendants as the sand of the sea, which cannot be numbered because they are many.' "

### Moses' prayer in affliction (Num 11:4-25)

After the people had eaten the manna that God had sent them from heaven, Moses heard the people weeping at the door of their tents. They were not satisfied with the heavenly food; instead, they wanted the meat they had eaten back in Egypt. How would you feel if you were God or Moses? You've already done the best to feed this great multitude of people, only to have them complain. The anger of the Lord was greatly aroused, and Moses was very displeased.

Moses shared his suffering by praying to the Lord. He said, "Why have You **afflicted** Your servant? And why have I not found favor in Your sight, that You have laid the burden of all these people on me? Did I conceive all these people? Did I give birth to them, that You should say to me, 'Carry them in your bosom, as a guardian carries a nursing baby,' to the land which You swore to their fathers? Where am I to get meat to give to all these people? For they weep and complain to me, saying, 'Give us meat, that we may eat.' I am not able to bear all these people alone, because the burden is too heavy for me. If You treat me like this, please kill me here and now—if I have found favor in Your sight—and do not let me see my wretchedness!"

The Lord replied to Moses, "Gather to Me seventy men of the elders of Israel. These men should be the elders of the people and officers over them. Bring them to the tabernacle of meeting, that they may stand there with you. Then I will come down and talk with you there. I will take of the **Spirit** that is upon you and will put the same upon them. These men shall bear the burden of the people with you, so you may not bear it alone. Then, you will say to the people, 'Consecrate yourselves for tomorrow, and you will eat meat. You have wept to the Lord, saying, "Who will give us meat to eat? For it was well with us in Egypt." The Lord will give you meat, and you will eat. You will not eat for one day, nor two days, nor five days, nor ten days, nor twenty days, but for a whole month, until it comes out of your nostrils and becomes hateful to you, because you have despised the Lord who is among you. You cried to Him, saying, "Why did we ever come up out of Egypt?" "

Moses said, "There are six hundred thousand men, yet You have said, 'I will give them meat, that they may eat for a whole month.' Will flocks and herds be slaughtered for them and all the fish of the sea gathered for them to provide enough for them?" Would you have believed that it would be possible to feed that many people in the desert? The Lord replied, "Has the Lord's arm been shortened? Now you will see whether what I say will happen to you or not."

Moses went out and told the people God's words. He gathered the seventy elders and placed them around the tabernacle. Then the Lord came down in the cloud, and spoke to Moses. God took the Spirit that was upon Moses, and placed the same upon the seventy elders. When the Spirit rested upon them, they prophesied, although they never did it again.

**Hannah's prayer for a son (1 Sam 1-2:11)**

There was a man of Ramathaim Zophim, in the mountains of Ephraim. His name was Elkanah, the son of Jeroham, the son of Elihu, the son of Tohu, the son of Zuph, an Ephraimite. He had two wives: Hannah and Peninnah. Peninnah had children, but Hannah had none.

Elkanah went up from his city yearly to worship and sacrifice to the Lord of hosts in Shiloh. Eli's two sons, Hophni and Phinehas, the priests of the Lord, were there. Whenever the time came for Elkanah to make an offering, he would give portions to Peninnah and to all her children. But to Hannah he would give a double portion because he loved Hannah, although the Lord had closed her womb.

Peninnah, her rival, provoked her severely, making Hannah miserable because she had no children. Year after year, when Hannah went up to the house of the Lord, Peninnah would mock her. Hannah was so upset from her lack of a child that she wept and did not eat. Her husband said to her, "Hannah, why do you cry? Why don't you eat? And why is your heart grieved? Am I not better to you than ten sons?" Can you imagine how terribly sad Hannah must have been because she couldn't have children and because of Peninnah's bullying?

After they had finished eating and drinking in Shiloh, Hannah went to the temple to pray, where Eli the priest was sitting on the seat by the doorpost of the tabernacle. Hannah felt great sadness and bitterness in her soul, so she prayed to the Lord and wept in **anguish**. Then, she made a vow and said, "O Lord of hosts, if You will truly look on the affliction of Your maidservant and remember me, and not forget me, but will give Your maidservant a male child, then I will give him to the Lord all the days of his life, and no razor will come upon his head."

As Hannah continued praying before the Lord, Eli watched her mouth. Hannah prayed in her heart, only her lips moved, but her voice was not heard. Eli thought she was drunk. Then, Eli said to Hannah, "How long will you be drunk? Put your wine away!" Hannah answered and said, "No, my lord, I am a woman of sorrowful spirit. I haven't drunk wine nor intoxicating drink, but have poured out my soul before the Lord. Do not consider your maidservant a wicked woman, for out of the abundance of my complaint and grief I have prayed until now." Then Eli answered and said, "Go in peace. May the God of Israel grant the petition you have asked of Him." Hannah replied, "Let your maidservant find favor in your sight." She went on her way and ate, and her face was no longer sad. When we have given our suffering and grief to God through prayer, trusting Him to do what is best, we no longer feel scared or distressed.

Hannah's family rose early in the morning and worshiped

before the Lord. Then, they returned to their house at Ramah. Elkanah knew Hannah his wife, and the Lord **remembered** her. In this process, Hannah conceived and bore a son. She called his name Samuel, saying, "Because I asked for him from the Lord."

Elkanah and all his family went up to offer the yearly sacrifice and his vow to the Lord. Hannah did not go up, saying, "Not until the child is weaned. Then, I will take him, so he may be before the Lord and remain there forever." Elkanah her husband replied to her, "Do what seems best to you. Wait until you have weaned him. Let the Lord establish His word." She stayed and nursed her son until she had weaned him.

When Hannah had weaned him, she took him up to the house of the Lord in Shiloh. She brought along three bulls, one ephah of flour, and a skin of wine. After sacrificing the bull, they brought the child to Eli, and Hannah said, "O my lord! As your soul lives, my lord, I am the woman who stood by you here, praying to the Lord. I prayed for this child, and the Lord has granted me the prayer I asked of Him. Therefore I also have lent my son to the Lord. As long as Samuel lives, he will be lent to the Lord." Then, they worshiped the Lord there. It was from that point onward that Samuel served as a dedicated servant to the Lord.

**Solomon's prayer for wisdom (1 Kgs 3:4-15)**

King Solomon went to Gibeon to sacrifice at the great high place. Solomon offered a thousand burnt offerings on that altar.

The Lord appeared to Solomon in a dream at night. God said, "Ask! What shall I give you?" How would you answer if God asked you this question, and you could have anything you wanted?

Solomon said, "You have shown great mercy to Your servant David my father, because he walked before You in truth, in righteousness, and in uprightness of heart. You have continued this great kindness for him, and You have given him a son to sit on his throne. Now, O Lord my God, You have made Your servant king instead of my father David, but I am a little child. I do not know how to go out or come in.

Your servant is in the midst of Your people whom You have chosen, a great people, too numerous to be numbered or counted. Therefore, give Your servant an **understanding** heart to judge Your people, that I may discern between good and evil. For who is able to judge this great people of Yours?"

Solomon's prayer **pleased** the Lord. God replied to him, "Because you have asked this thing, and have not asked

long life for yourself, nor have asked riches for yourself, nor have asked the life of your enemies, but have asked for yourself understanding to discern justice, behold, I have done according to your words. I have given you a wise and understanding heart, so that there has not been anyone like you before you, nor shall any like you arise after you. I have also given you what you have not asked: both riches and honor, so that there shall not be anyone like you among the kings all your days. So if you walk in My ways, to keep My statutes and My commandments, as your father David walked, then I will lengthen your days."

Then, Solomon awoke from his dream. He came to Jerusalem and stood before the ark of the covenant of the Lord, offered up burnt offerings, offered peace offerings, and made a feast for all his servants.

#### FOR TEACHERS

Hand out Bible Discovery Worksheet #2 to the students now and guide them to fill in the table. Refer to the Teacher Version for answers.

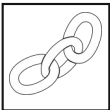

## Linking to the Ten Basic Beliefs

2-5 Minutes

The Holy Spirit is a Spirit of understanding and wisdom. Whatever we may be going through, whatever troubles we may be struggling with, or whatever conflict we may be facing, the Spirit knows, understands, and intercedes with God for our sakes. Whenever we pray, the Spirit is also praying for us to God so that He might help us and guide us. It empowers our prayers. It is with this in mind that we should always seek to obtain the Holy Spirit, and then fill ourselves with the Spirit so that whatever trial we face, we can go through it with God's comfort, wisdom, and guidance.



## Check for Understanding

5 Minutes

1. **Why was Jacob afraid of Esau?** He thought Esau was still angry and would attack him and his family.
2. **What did God promise Jacob?** He promised that his descendants would be numerous.
3. **Why was Moses frustrated?** The Israelites were complaining about not having meat to eat.
4. **How did God solve Moses' problem?** He placed the Spirit on seventy elders who could help Moses.
5. **Why was Hannah sad?** She was barren, and her husband's other wife provoked her.
6. **What did Hannah do with the prayer God had answered?** She brought Samuel to serve in God's temple.
7. **What did Solomon ask for?** He prayed for wisdom to judge the people of God.
8. **What other things did God grant Solomon?** He granted Solomon riches, honor, and a long life if he walked according to God's ways.



## Life Application

10 Minutes

### 1. Prayer Works

[Hand out Life Application Worksheet #1 and guide the students to complete the first half. Then, read the scenarios aloud with the students, and ask them to share their answers to the questions.]

### 2. Keeping Up with Prayer

[Hand out Life Application Worksheet #2. Emphasize to the students the importance of keeping a regular prayer habit, and then give the students time to complete the worksheet on their own. You can ask the students to share their answers when everyone has finished, or simply tell them to keep this in their notebooks as a reminder to pray always. If the students are having difficulty, you can complete this worksheet yourself as an example and share your answers with them.]



## Activity

### Matchbox Mezuzah

10-15 Minutes

**Objective:** To remind students to be committed to prayer by placing this scroll on the student's bedroom door.

A mezuzah, which literally means "doorpost in Hebrew," is a small scroll traditionally mounted to every doorpost in a house to mark a family's commitment to creating a Jewish household. Today, the students will be making one for their bedroom door to remind them to pray.

#### Materials

- Empty matchbox
- Masking tape
- Popsicle stick
- Tissue paper in various colors, cut into 10-15 one-inch squares
- Sheets of white paper, cut into 10-15 one-inch squares
- White glue
- Small paintbrush
- Pen, rubber stamp, glitter glue, or stickers
- Adhesive gems, beads, ribbon, etc. (optional)

#### Instructions

1. Tape the popsicle stick to the back of the matchbox lengthwise. Don't tape the box shut.
2. Brush a thin layer of glue on the matchbox, gluing over the tape as well.
3. Press individual layers of the tissue squares on the box, skipping the open ends. Keep brushing on glue and pressing layers.
4. Add decorations to the matchbox.
5. Write a prayer or several prayers on one small square of white paper.
6. Roll up the paper and insert it into the matchbox.
7. Tell the students to mount the mezuzah on their bedroom door with masking tape.

#### HOMEWORK ANSWER KEY

1. Jacob prayed for Esau's mercy on his family. God promised his descendants would be many.
2. Moses prayed about his frustrations with the people. God gave His Spirit to seventy elders to help him.
3. Hannah prayed for a son. God granted her a son, Samuel, and she dedicated Samuel to the service of the temple.
4. Solomon prayed for wisdom. In addition to wisdom, God granted Solomon riches, honor, and a long life if he followed God's commandments.
5. Answers may vary.

### FOUR GREAT PRAYERS IN THE OLD TESTAMENT

The four prayers we learned about today were each a different type of prayer. In the boxes below, write down the biblical definition of the word listed in the first column, and then write what could have happened to each of the people if they had not prayed to God.

Type of Prayer	Biblical Definition	Bible Illustration	Possible Results Without Prayer
<p style="text-align: center;"><b>Mercy</b> (Jacob)</p>	<p style="text-align: center;"><i>To show love and kindness, especially when a person does not deserve it.</i></p>	<p style="text-align: center;">For I desire mercy and not sacrifice, And the knowledge of God more than burnt offerings.  (Hosea 6:6)</p>	<p style="text-align: center;"><i>Esau may have attacked, hurt, or even killed Jacob, his family, his servants, and his livestock.</i></p>
<p style="text-align: center;"><b>Affliction</b> (Moses)</p>	<p style="text-align: center;"><i>A state of deep grief, suffering, and pain.</i></p>	<p style="text-align: center;">Many are the afflictions of the righteous, But the Lord delivers him out of them all.  (Psalm 34:19)</p>	<p style="text-align: center;"><i>Moses would have been crushed by the great pressure and demands of the ungrateful Israelites.</i></p>
<p style="text-align: center;"><b>Prayer for a Special Need</b> (Hannah)</p>	<p style="text-align: center;"><i>A situation that no human will or power can resolve.</i></p>	<p style="text-align: center;">When my soul fainted within me, I remembered the Lord; And my prayer went up to You, Into Your holy temple.  (Jonah 2:7)</p>	<p style="text-align: center;"><i>Hannah would have remained childless and been sad and bitter for the rest of her life.</i></p>
<p style="text-align: center;"><b>Wisdom</b> (Solomon)</p>	<p style="text-align: center;"><i>A high level of understanding that comes from God.</i></p>	<p style="text-align: center;">If any of you lacks wisdom, let him ask of God, who gives to all liberally and without reproach, and it will be given to him.  (James 1:5)</p>	<p style="text-align: center;"><i>Solomon would not have been able to rule God's people with understanding and justice.</i></p>



**FOUR GREAT PRAYERS IN THE OLD TESTAMENT (PART 1)**

Fill in the blanks as you go through the lesson.



**1. Jacob's prayer for mercy from Esau (Gen 32:3-12)**

When Jacob prayed to God, he told Him that he was not worthy of the least of all God's \_\_\_\_\_. He also asked God, "\_\_\_\_\_ me, I pray, from the hand of my brother Esau" because he was very afraid, and knew that only God could help him.

**2. Moses' prayer in affliction (Num 11:4-25)**

When the Israelites complained, Moses was very displeased with them and asked God, "Why have You \_\_\_\_\_ Your servant?" In response, God directed Moses to take seventy elders. He told Moses that He would place His \_\_\_\_\_—the same that was in Moses—upon them to empower them so that they could also share Moses' burdens.



**3. Hannah's prayer for a son (1 Sam 1-2:11)**

When Hannah prayed to the Lord, it was because she was feeling great \_\_\_\_\_. Her voice was heard by God, because later, after her desperate prayer, the Lord \_\_\_\_\_ her and gave her a son, just as she had requested.

**4. Solomon's prayer for wisdom (1 Kgs 3:4-15)**

When God asked Solomon what He should give to him, Solomon prayed for an \_\_\_\_\_ heart so that he could rule God's people. Solomon's humble request \_\_\_\_\_ the Lord so much that He not only gave Solomon understanding, He also gave him great wisdom so that many people from around the world came to meet Solomon and speak with him.





**FOUR GREAT PRAYERS IN THE OLD TESTAMENT (PART 2)**

The four prayers we learned about today were each a different type of prayer. In the boxes below, write down the biblical definition of the word listed in the first column, and then write what could have happened to each of the people if they had not prayed to God.

Type of Prayer	Biblical Definition	Bible Illustration	Possible Results Without Prayer
<p><b>Mercy</b> (Jacob)</p>		<p>For I desire mercy and not sacrifice, And the knowledge of God more than burnt offerings.</p> <p>(Hosea 6:6)</p>	
<p><b>Affliction</b> (Moses)</p>		<p>Many are the afflictions of the righteous, But the Lord delivers him out of them all.</p> <p>(Psalm 34:19)</p>	
<p><b>Prayer for a Special Need</b> (Hannah)</p>		<p>When my soul fainted within me, I remembered the Lord; And my prayer went up to You, Into Your holy temple.</p> <p>(Jonah 2:7)</p>	
<p><b>Wisdom</b> (Solomon)</p>		<p>If any of you lacks wisdom, let him ask of God, who gives to all liberally and without reproach, and it will be given to him.</p> <p>(James 1:5)</p>	

**PRAYER WORKS**

**Based on the four prayers in the Old Testament that we studied today, we learned that:**

1. We can pray in any and every circumstance.
2. Prayer makes the impossible, possible.

**Please answer the following questions.**

1. How would each of their situations have turned out if they hadn't prayed to God?

Jacob \_\_\_\_\_

Moses \_\_\_\_\_

Hannah \_\_\_\_\_

Solomon \_\_\_\_\_

2. List three things you would like to pray for and explain why.

a. \_\_\_\_\_

b. \_\_\_\_\_

c. \_\_\_\_\_

3. Describe a time when you or a loved one experienced the power of prayer.

\_\_\_\_\_

\_\_\_\_\_

\_\_\_\_\_

\_\_\_\_\_

**Testimonies of Answered Prayers**

a. Before a brother started pursuing Christ, he stole his friend's car. After he came to believe, he was called before the judge to receive a punishment for his crime. While the brother was on his way to the court, he prayed to God and asked for mercy, as he had committed the thievery before he came to know Christ and while he was under negative influences. To his surprise, the judge decided to let him go with a warning never to commit a crime again.

If you were this brother, how would you have tried to fix this situation on your own? How would that have turned out?

\_\_\_\_\_

\_\_\_\_\_

\_\_\_\_\_

\_\_\_\_\_



b. A sister was in great distress because her three small children were very sick with fever. She was alone in a foreign land, it was late at night, and there was no one around to help her. The sister knelt down and started praying for her children. Suddenly, her eldest daughter woke up, her fever gone. The daughter knelt next to the sister, and they both prayed over the two younger children. In a matter of minutes, the fever had disappeared among all three.



When you are sick or in pain, what is the first thing you usually do? How effective is that compared to praying?

---



---

c. A brother was making a dangerous journey to his new home. During this trip, he had to sail on a small boat, in the middle of a stormy ocean. As the waves, rain, and wind swept around him and threatened to capsize his boat, the brother prayed to God for deliverance. It was such a tiny vessel on violent waters that his chances for survival were slim to none. Hope was quickly disappearing. The brother commended himself to God, and promised to seek Him wholeheartedly if he was allowed to make it safely to land. The storm ceased, the waves calmed. Within days, he was safely ashore and on the way to his new home.

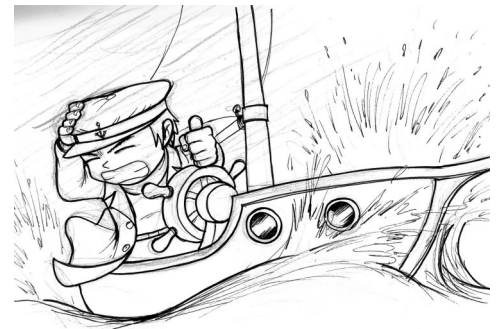

When things seem impossible to resolve, what feelings crowd around your heart and mind? What difference does prayer make in these situations?

---



---

d. During her senior year of high school, a sister faced a very important decision. On the one hand, she could choose to go to a very well-known university with no church or fellow members nearby. On the other hand, she could attend a less famous one close to a church. The decision was very difficult because she had always pictured herself going to the more prestigious school, and her classmates kept telling her what a great opportunity it was. Her parents and fellow church brothers and sisters, though, recommended that she stay closer to church, as college years were often full of spiritual trials, and she may need support from fellow brothers and sisters. She prayed to God for the wisdom to make the best choice. In the end, her prayers directed her to choose the school near church, and it proved to be one of the best decisions she ever made.



When everyone around us seems to be giving us conflicting ideas, whom do we follow? How does God guide us through prayer when this happens?

---



---

**KEEPING UP WITH PRAYER**

It is important to keep up a habit of praying in order to maintain our relationship with God. Reflect upon your prayer habits, and then complete the sentences below.

I think prayer is important because \_\_\_\_\_

---

---

When I don't pray, I notice that \_\_\_\_\_

---

---

It is difficult to keep up prayer every day because \_\_\_\_\_

---

---

---

Some ways that I have seen other maintain a good habit of prayer are \_\_\_\_\_

---

---

---

---

E2 Year 2 Book 2 Lesson 7—Four Great Prayers in the Old Testament

# Homework Assignment

Name: \_\_\_\_\_ Parent signature: \_\_\_\_\_ Date: \_\_\_\_\_

Weekly Bible Reading: \_\_\_\_\_

**Bible Reading:** Check each box when you complete that day's reading.

**Prayer:** Check each box after you pray to God that day.

	Sun	Mon	Tue	Wed	Thu	Fri	Sat
Read							
Pray							

## What I Learned from the Bible This Week

1. \_\_\_\_\_  
 \_\_\_\_\_  
 \_\_\_\_\_
2. \_\_\_\_\_  
 \_\_\_\_\_  
 \_\_\_\_\_

## Memory Verse

Please write down this week's memory verse. (1 John 5:14)

\_\_\_\_\_

**Four Great Prayers:** For each of the following, explain what they prayed for and what God granted them in the end.

1. Jacob: \_\_\_\_\_  
 \_\_\_\_\_
2. Moses: \_\_\_\_\_  
 \_\_\_\_\_
3. Hannah: \_\_\_\_\_  
 \_\_\_\_\_
4. Solomon: \_\_\_\_\_  
 \_\_\_\_\_

## Short Answer

5. If you could ask God for anything and know that He would grant your request, what would you pray for?

\_\_\_\_\_  
 \_\_\_\_\_  
 \_\_\_\_\_

# LESSON 8

## JESUS' GREAT PRAYER

### OBJECTIVES

1. To understand that we bring glory to Him so that Jesus might be glorified.
2. To understand that we will be sanctified and the church must be unified.
3. To understand that the word is evangelized.

### MEMORY VERSE

"Let us therefore come boldly to the throne of grace, that we may obtain mercy and find grace to help in time of need."

(Hebrews 4:16)

### PRAYER

Hallelujah, in the name of the Lord Jesus, we pray. Dear Lord, we thank You for granting us this wonderful Sabbath day so that we may come before You to worship You. Lord, we pray that You help us to glorify You and to do Your will every day. Please protect and guide us so that we can grow up healthy and happy. Please remind us when we sin against You and forgive our sins. Lord, please help us get along with everyone around us, including our parents, siblings, church brothers and sisters, and friends at school. Please help us to overcome temptations. Please prepare our hearts so that we can concentrate and learn Your word in class today, and help us to remember the lesson and act it out in our everyday lives. May all the glory be unto Your name. Amen.



### Overview

#### 1. Jesus' Great Prayer (John 17)

- We bring glory to Him so that Jesus might be glorified.
- We will be sanctified.
- The church must be unified.
- The word is evangelized.

#### 2. Linking to the Ten Basic Beliefs—One True God

#### 3. Life Application

- Jesus Christ Is Our Spiritual High Priest
- Jesus' Great Prayer

#### 4. Activity

- Vocabulary Detective
- Four Corners



### Background Knowledge for Teachers

When the disciples asked Jesus to teach them how to pray, He responded with a model prayer, usually called "The Lord's Prayer." But, if we turn to John, chapter 17, we can find the high priestly prayer of the Lord Jesus. John, chapter 17 is a chapter which one may perhaps characterize truly as unequalled in depth and scope in all of the Scriptures. Studying this prayer reveals Christ's perfect will for us. This is exactly our privilege in John, chapter 17. The Lord has enabled us to turn our eyes to His praying, and when we finish listening to Him pray, we will know what is on His agenda. This is so exciting! When we read John, chapter 17, we discover four things.

1. We bring glory to Him that Jesus might be glorified (vv. 1, 5). We discover His intense desire that He be glorified. How do we do this? We do so by making sure our actions reflect well on our Savior. When people gain a taste of heaven by sampling the righteous deeds and attitudes we display, Jesus is glorified.
2. We will be sanctified (vv. 11, 15). Repeatedly throughout His prayer we find that the heartbeat of Jesus is for God's people to be sanctified. Jesus' desires that the people of God should be holy, righteous, sanctified, and set apart from the world.
3. The church will be unified (vv. 21-23). God desires for His church to be unified. What does He mean? He is talking about the spiritual unity of all true members of the body of Christ. Do we lack unity among believers?



4. The word is evangelized (v. 18). Why did Jesus come into the world? To seek and to save that which was lost. And why are we sent into the world? To seek and to save that which is lost. In the second half of verse 21, Jesus asked the Father that the church might be unified so that the world may believe that He sent Him. The Father had sent Jesus from heaven to earth to redeem a people for His very own. Jesus' heart beat for evangelism and missionary outreach, and He desires that all people might be saved.

### **Conclusion**

We need to bathe ourselves in the Lord's deepest concerns. One of the best ways to do that is to meditate and understand His prayer in John, chapter 17. So, here is the question: If Jesus Christ is God, why does He have to pray? This is the answer: When He walked upon this earth, Jesus lived in obedience and depended upon the Father. He did this to give us an example of how to live (Heb 5:7-8). So if Jesus Christ, with all His power and perfection, made prayer a priority in His life, then, we should also make a place for prayer in our lives as well.

We can see the importance of the Great Prayer by focusing on the time and place it was said. It was spoken during the night on which Jesus was betrayed, inside the house where He had the Last Supper and had washed His disciples' feet (Jn 18:1; Jn 13). It happened after He had taught His faithful disciples plainly, especially about heaven, His second coming, and the coming Holy Spirit as the Helper and guide to the truth (Jn 14:1-4, 15-18, 26, 28; 16:5-15, 25). At that time, He also commanded them to abide in Him, the True Vine, through love and bearing fruit, because of the coming tribulation when the world would hate them (Jn 15-16:4). It was as though this was done to reinforce all of His teachings to His disciples and to ask God to keep them (Jn 17:11). Immediately after the Great Prayer, Jesus and His disciples went out to the garden to pray (this time, a prayer of sorrow and anguish because of the suffering which He knew He was about to go through as the sacrificial Lamb—cf. Mt 26:38; Lk 22:44).

It is advised that the teacher should understand the role of Jesus as the High Priest as described in the book of Hebrews. Here is a summary of the passages in Hebrews as quoted from Bible Study Guide: Philemon and Hebrews, published by True Jesus Church Department of Literary Ministry (2001), page 19:

#### Christ the High Priest

Like the earthly high priests, Christ was appointed by God as the High Priest (5:4,5) to offer gifts and sacrifices for sins (5:3; 8:2,3). Unlike the earthly high priests, Christ was sinless (7:26), became the High Priest in the order of Melchizedek (5:6,10; 6:20; 7:17), was appointed with an oath (7:20-21), offered His own body as a perfect sacrifice once for all (7:27; 10:12), lives forever and sanctifies us forever (7:24,28; 10:14).

Christ has entered the heavenly sanctuary on our behalf, granting us the privilege to draw near to God through His blood (10:19-22). He is a High Priest who is merciful and sympathizes with our weakness (2:17; 4:15). Thus we may "come boldly to the throne of grace, that we may obtain mercy and find grace to help in time of need" (4:16).

Above all, He is the source of our eternal salvation (5:9), the author and finisher of our faith (12:2). He continues to intercede for us (7:25) and has perfected forever those who are being sanctified (10:14). Therefore, by the sacrifice of Jesus Christ, the perfect and ultimate High Priest, we have the assurance of salvation as an anchor for the soul (6:19).

The purpose of a priest is to be a mediator between man and God, especially to pray to God on behalf of man. In John, chapter 17, Jesus, the perfect High Priest, prayed to the heavenly Father on behalf of His disciples and of all the believers who are to come. The Great Prayer was said for our edification also, that we His disciples could know His perfect will for us. As we read the words of our High Priest Jesus in the Great Prayer, we remind ourselves that this is His prayer for us forever, as He continues to make intercession for us as High Priest in heaven (Heb 7:24-25).



## Reaching Out to Your Students

E2 students probably have already had a lot of experience in church praying in the spirit, especially for the Holy Spirit. At this age, some of them may already have received the Holy Spirit, but if they have not, they are usually taught to concentrate on just one thing during prayer, which is asking for the Holy Spirit. In the minds of the students, probably little emphasis is put on prayer in understanding. However, one of the purposes of prayer in understanding is to edify the church (1 Cor 14:19). When we gather and pray in understanding, whether it be lunch grace or the prayer at the beginning of class, if we listen carefully to the words of the prayer, we will be edified, and when we all say, "Amen," at the end of the prayer, it means that we all agree that what we have just prayed is true and sincere.

Ask your students at the beginning of the lesson to listen carefully to the words of the prayer in understanding that you say, and quiz them by asking them what they have learned from the prayer. Let your students know that when we pray in understanding, we use words so that everyone can understand and be edified, or learn something good from it. Tell them that one way to help them concentrate better in their prayer in spirit is to think of a prayer in understanding and talk to God as if they were saying a prayer in understanding. Finally, tell them that today we will read a prayer of Jesus that He said in understanding that had powerful words that would help His disciples in ancient times as well as us today.



## Opener

*5 Minutes*

In the last few lessons, we have learned about prayer. First, we talked about the meaning of prayer. Boys and girls, can you tell me what is the meaning of prayer? [Let students respond freely.] Then, we talked about the Lord's Prayer, which is something that we recite a lot after prayer in tongues. Boys and girls, can you tell me some of the important lessons you learned from the Lord's Prayer? [Let students respond freely.]

Today, we'll learn about Jesus' Great Prayer. Did you know that Jesus prayed while He was in the world? Jesus is God, but why did He have to pray? [Let students respond, if you want. Otherwise, just continue.] Jesus is indeed God, but while in the world, He had a physical body, just like every one of us, so He was limited by time and space like us. What does it mean to be limited by time and space? It means that you can only be in one place at one time, you can't travel backwards or forwards in time, and you can't suddenly disappear from one place and appear in another instantly. It means that, while He was in the world, Jesus started out as a baby and grew up into a child and then an adult as time passed by. To go from place to place, He walked around. It was only after Jesus rose from the dead that He was able to appear and disappear. While in the flesh, Jesus needed the help of the heavenly Father to overcome His difficulties, and that is why He prayed. Jesus prayed for Himself whenever He was preaching and healing people so that He would have power, and He prayed in the garden of Gethsemane before His crucifixion so that He would be able to face the pain of crucifixion.

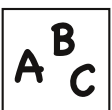

## Vocabulary

**glorify:** to reveal or make clearer the glory of God by one's actions; to give praise to God

**authority:** the power or right to give orders, make decisions, and enforce obedience

**manifested:** shown

**son of perdition:** a sinner who refuses to repent and has died, and thus is eternally condemned (in this case, Judas Iscariot)

**fulfilled:** completed; satisfied and happy

**sanctify:** to make a person holy

**foundation of the**

**world:** the time in the beginning when God created the world

**declare:** to say something with emphasis; to announce



## Bible Discovery & Spiritual Teaching

30-35 Minutes

The Great Prayer of Jesus that we will learn about today is very different from the other prayers of Jesus. In this prayer, Jesus is not praying for God's help merely because He is in the flesh. Rather, He is praying as the High Priest. Let's fill in Worksheet #1.

### FOR TEACHERS

In this lesson, the Life Application section has been integrated into the Bible Discovery & Spiritual Teaching. Hand out Bible Discovery Worksheet #1 to the students. Write the chart on the board. Ask the students to turn to the Bible verses and volunteer the answers. If the students are having difficulty finding the answers, guide them along and provide the answers.

Boys and girls, we can learn from this worksheet that Jesus is our spiritual High Priest, because He sacrificed Himself for our sins and now lives forever in heaven. Because of Jesus' perfect sacrifice that can wash away all of our sins, we no longer need priests like in the Old Testament. In the Old Testament, ordinary people dared not to pray to God directly without the priest being there to make a sacrifice for their sins at the temple, but now in the New Testament, because of Jesus Christ, each one of us can come boldly to God and pray to Him anytime, anywhere! What a wonderful Savior is Jesus Christ our Lord!

We also learned that the high priest should pray for the people. Jesus, our spiritual High Priest, prayed a Great Prayer recorded in John, chapter 17.

### FOR TEACHERS

Give Worksheet #2 to the students. First, go over the vocabulary in Worksheet #2 by following the instructions in Activity #1: Vocabulary Detective. At the end of the activity, be sure to go over the answers and ask the students if they have any questions about the vocabulary words.

Boys and girls, please open your Bibles to John, chapter 17. It was the night before Jesus was to be crucified. Do you remember what happened on that night? [Let students answer freely.] Now, Jesus and His disciples had just finished eating the Last Supper, Jesus had already washed His disciples' feet, and He was telling them very important teachings. Finally, before going out to the garden of Gethsemane, Jesus prayed this Great Prayer as the spiritual High Priest before performing the sacrifice. In this prayer, we will learn about the Lord Jesus' will for us as His believers and His disciples. Let's read John, chapter 17; this whole chapter is Jesus speaking, and He is praying to God as our spiritual High Priest.

### FOR TEACHERS

Using an audio Bible here is highly recommended, but if one is not readily available, then ask the students to take turns reading. While the students are reading, divide the board into four areas: glorified, sanctified, unified, and evangelized.

Boys and girls, after reading this passage, can you find some of the things that Jesus prayed for? [Let the students answer freely while you write their answers on the board, putting them into the appropriate sections.] Great observations, everyone! Now let's look deeper into Jesus' Great Prayer.

### FOR TEACHERS

Hand out Worksheet #3 to the students now and go over the instructions.

First, let's do Column A as a class. From verses 1 and 5, what did Jesus pray about? (Jesus desires to be glorified.) That's right! Please write "glorified" in the blank. [Lead the students to fill in the rest of the blanks in Column A: sanctified, unified, and evangelize.] Great job, everyone! In Column B, please write how we can fulfill Jesus' desires. Let's go over the first example. Looking at our vocabulary list, what does glorify mean? That's right, it means to praise God. So, we can fulfill Jesus' desires to be glorified by praising Him. Now, let's look at Column C. What can we do to glorify or praise Him? The example says, "I can sing hymns aloud often to glorify God." What else can we do to glorify God? Please write them down.

### FOR TEACHERS

See if the students have any questions about this worksheet, and then ask them to complete the rest on their own. You may need to walk around the classroom to see if they need any help. If some of the students finish Worksheet #3 faster than others, ask them to help the students who are still working on it.

Boys and girls, we have learned these few weeks about prayer, including the meaning of prayer, the Lord's Prayer, and today, Jesus' Great Prayer. We have learned that prayer is so precious because we have this privilege to come before God and tell Him whatever is in our hearts. Finally, please open your Bibles to Hebrews 4:16, which is your memory verse, "Let us therefore come boldly to the throne of grace, that we may obtain mercy and find grace to help in time of need."



## Linking to the Ten Basic Beliefs

2-5 Minutes

### One True God

This lesson emphasizes the belief that there is only one true God, Jesus Christ, who is one with the heavenly Father. Jesus Christ was with God in the beginning and was God (Jn 1:1), but was not manifest to the world until about 2000 years ago when He became flesh to come into the world (1 Pet 1:20). As fully God and fully human, Jesus had the authority of God, but He still needed to pray to God. He did this as an example for us and to encourage us with the words of His prayer. In the Great Prayer, Jesus Christ executes His power as the High Priest to pray to God as the mediator for the believers.



## Check for Understanding

5 Minutes

### True or False/Multiple Choice/Fill In the Blank

1. **Jesus is our spiritual High Priest because He sacrificed Himself for our sins.** True.
2. **The High Priest of the New Testament must be a son of Aaron.** False; the High Priest in the New Testament is our Lord Jesus Christ.
3. **It's okay if the members in church don't get along, as long as they all believe in God.** False; God wants the church to be unified.
4. **Jesus prayed the Great Prayer after the Last Supper where He washed His disciples' feet and before going to the garden of Gethsemane.** True.
5. **High priests in the Old Testament were not perfect because \_\_\_\_\_.**
  - a. They had sins themselves.
  - b. They didn't live forever.
  - c. Both A and B.
6. **Another word for glorify is \_\_\_\_\_ (praise).**
7. **Another word for sanctify is to be \_\_\_\_\_ (holy).**
8. **Another word for evangelize is \_\_\_\_\_ (preach).**



## Activity

### 1. Vocabulary Detective / 2. Four Corners

10-15 Minutes

#### 1. Vocabulary Detective

**Objective:** To reinforce the vocabulary words.

#### Instructions

1. Print out or write each vocabulary word and its definition in large font on separate pages.
2. Underline the words that the students should fill in on Worksheet #2.
3. Post these "clues" (each page) in random areas around the classroom before class starts.
4. When you get to Worksheet #2 in the lesson, instruct the students to bring their worksheet and a pencil with them, and walk around the classroom to find the answers to fill in the blanks for the vocabulary words.
5. When the students are finished, go over the answers.

#### 2. Four Corners

**Objective:** To emphasize how we can live out the different aspects of Jesus' Great Prayer.

#### Preparation

1. Write "Glorify God," "Be sanctified," "Church is unified," and "Evangelize" on four different sheets of paper in large print.
2. Post the four sheets of paper in the four corners of the classroom.



**Instructions**

This activity can be done at the end of the class because it involves a lot of moving around. Below are twenty-five different sentences, each pertaining to at least one of the four phrases posted in each corner.

1. Have the students stand up and move their desks away from the center of the room, if possible, so that they have space to walk without bumping into things.
2. Instruct the students to look at the four phrases posted in the corners of the room. Tell the students that you will be reading different sentences.
3. After you read a sentence, you will say, "Go," and the students must move to the corner of the room with the phrase they think matches the sentence you just read.
4. When all of the students have settled down in their corners, call on a student from each corner and ask why they chose that corner (sometimes there can be more than one "right" answer).
5. After the students have finished sharing, read the next sentence.
6. To make the game shorter, choose fewer sentences and/or fewer people to share. To make the game longer, make your own sentences, or pick from the students' answers in Worksheet #3, Column C.

*Amy likes to praise God by singing in choir.*

*Bobby tries to get along with everyone in RE class.*

*Christine brought her friend to a hymnal evangelical service.*

*David doesn't watch violent movies even though his friends do.*

*Eva helps clean the church love hall.*

*Fred wears his TJC T-shirt proudly to school.*

*Grace says grace before she has lunch at school.*

*Henry helps his parents give flyers to strangers at the shopping center.*

*Irene got 100% on her test; when her parents said, "Great job!" she said, "Thank God!"*

*Jack sat with the new kid during lunch at church.*

*Kathy led the whole class in singing hymns.*

*Luke went with the evangelical team to the local hospital.*

*Michelle keeps herself holy by not saying any bad words.*

*Nelson asked the older kids very nicely to be quiet during service.*

*Olivia shared a testimony about how God helped her get better when she was sick.*

*Peter helped explain prayer in tongues to the new truth-seekers.*

*Quincy determined to pray for fifteen minutes every day.*

*Rosy asked her dad, who isn't baptized yet, to come to church with her.*

*Samuel praised God when older people complimented him.*

*Tammy doesn't copy her classmate's homework even though she hasn't finished hers.*

*Victor dresses up for church because the preacher encourages everyone to wear formal clothes to service.*

*Wendy prays earnestly for the Holy Spirit every Sabbath during prayer session.*

*Xavier listened to his parents when they asked him to stop playing video games.*

*Yvonne gave her best friend at school a birthday card she made with a Bible verse on it.*

*Zack plays piano for RE class.*

**HOMEWORK ANSWER KEY**

1. glorify—praise  
sanctify—make holy  
unify—bring together  
evangelize—preach
2. Answers may vary.
3. Refer to Bible Discovery Worksheet #1, Teacher Version for answers.

## JESUS CHRIST IS OUR SPIRITUAL HIGH PRIEST

	OLD TESTAMENT	NEW TESTAMENT
<p><b>Who is the high priest?</b> <i>(Hebrews 5:4-5)</i></p>	<i>Sons of Aaron</i>	<i>Jesus Christ</i>
<p><b>What is the high priest's job?</b> <i>(Hebrews 5:1-3; 7:24-25)</i></p>	<i>To make sacrifices for the sins of the people and pray for them</i>	<i>To make sacrifices for the sins of the people and pray for them; to make intercession for them</i>
<p><b>What kind of offerings and sacrifices does the high priest make?</b> <i>(Hebrews 10:4, 10)</i></p>	<i>Animals such as goats, sheep, and bulls, and their blood</i>	<i>Jesus' own body and blood</i>
<p><b>How often does the high priest have to make sacrifices?</b> <i>(Hebrews 7:26-28; 10:1-4, 11, 14)</i></p>	<i>Once a year on the Day of Atonement and also every day</i>	<i>Once and for all</i>
<p><b>Where does the high priest do his job?</b> <i>(Hebrews 9:6-7, 11, 24-25)</i></p>	<i>In the tabernacle</i>	<i>In heaven</i>
<p><b>What happens when the high priest dies?</b> <i>(Hebrews 7:23-24)</i></p>	<i>A new high priest will take his place</i>	<i>Jesus lives forever, so He is High Priest forever</i>
<p><b>Is the high priest a perfect person? Why or why not?</b> <i>(Hebrews 7:26-28)</i></p>	<i>No, the high priest has his own sins and he cannot live forever</i>	<i>Yes, Jesus is sinless and lives forever</i>





# JESUS CHRIST IS OUR SPIRITUAL HIGH PRIEST



	OLD TESTAMENT	NEW TESTAMENT
<p><b>Who is the high priest?</b> <i>(Hebrews 5:4-5)</i></p>		
<p><b>What is the high priest's job?</b> <i>(Hebrews 5:1-3; 7:24-25)</i></p>		
<p><b>What kind of offerings and sacrifices does the high priest make?</b> <i>(Hebrews 10:4, 10)</i></p>		
<p><b>How often does the high priest have to make sacrifices?</b> <i>(Hebrews 7:26-28; 10:1-4, 11, 14)</i></p>		
<p><b>Where does the high priest do his job?</b> <i>(Hebrews 9:6-7, 11, 24-25)</i></p>		
<p><b>What happens when the high priest dies?</b> <i>(Hebrews 7:23-24)</i></p>		
<p><b>Is the high priest a perfect person? Why or why not?</b> <i>(Hebrews 7:26-28)</i></p>		

# vocabulary detective

**Instructions:** Fill in the blanks for the vocabulary definitions.

**glorify:** 1. To \_\_\_\_\_ or make clearer the glory of God by one's actions.  
2. To give \_\_\_\_\_ to God.

**authority:** The \_\_\_\_\_ or right to give orders, make \_\_\_\_\_, and enforce obedience.

**manifested:** \_\_\_\_\_

**son of perdition:** A sinner who refuses to \_\_\_\_\_ and has died, and thus is eternally condemned (in this case, \_\_\_\_\_ [scariot]).

**fulfilled:** \_\_\_\_\_; \_\_\_\_\_ and happy

**sanctify:** To make a person \_\_\_\_\_.

**foundation of the world:** The time in the \_\_\_\_\_ when God created the \_\_\_\_\_.

**declare:** To say something with \_\_\_\_\_; to \_\_\_\_\_.

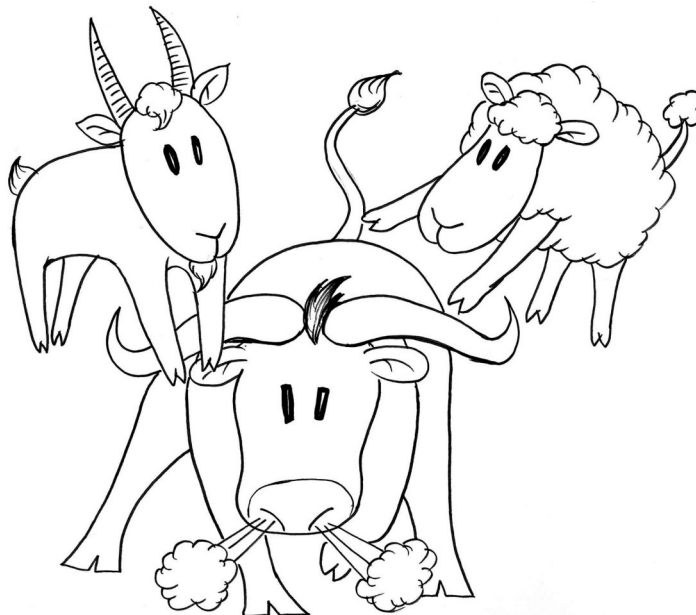

**JESUS' GREAT PRAYER**

**Instructions**

Column A: Work with your class to find the correct word to fill in the blanks using the hint from the verse numbers.

Column B: Work with your partner to figure out the answers. (Hint: What is the meaning of the word you filled in the blank in Column A?)

Column C: Work with your partner to fill in Column C.

	COLUMN A	COLUMN B	COLUMN C
Verses	What did Jesus pray about?	How can we fulfill Jesus' will for us?	Give 2 examples of what you can do to follow each point of Jesus' Great Prayer.
1, 5	Jesus desires to be _____.	<b>Example:</b> <i>Jesus wants us to praise Him.</i>	<b>Example:</b> (1) <i>I can sing hymns aloud often to glorify God.</i> (2)
11, 15	Jesus wants us to be _____.		(1) (2)
21-23	Jesus wills for the church to be _____.		(1) (2)
18	Jesus sends us out to _____.		(1) (2)

E2 Year 2 Book 2 Lesson 8—Jesus' Great Prayer

# Homework Assignment

Name: \_\_\_\_\_ Parent signature: \_\_\_\_\_ Date: \_\_\_\_\_

Weekly Bible Reading: \_\_\_\_\_

**Bible Reading:** Check each box when you complete that day's reading.

**Prayer:** Check each box after you pray to God that day.

	Sun	Mon	Tue	Wed	Thu	Fri	Sat
Read							
Pray							

## What I Learned from the Bible This Week

1. \_\_\_\_\_  
 \_\_\_\_\_  
 \_\_\_\_\_
2. \_\_\_\_\_  
 \_\_\_\_\_  
 \_\_\_\_\_

## Memory Verse

Please write down this week's memory verse. **(Hebrews 4:16)**

\_\_\_\_\_

1. Match the vocabulary words with their synonyms.

- |            |                |
|------------|----------------|
| glorify    | preach         |
| sanctify   | praise         |
| unify      | make holy      |
| evangelize | bring together |

2. Read John chapter 17, Jesus' Great Prayer. The main points that we learned are:

- (1) We bring glory to Him so that Jesus might be glorified.
- (2) We will be sanctified.
- (3) The church must be unified.
- (4) The word is evangelized.

Choose one of the points to write about. Write five sentences or more about why you think that point is important and how you will put that point into action.

3. Work with your parent. Read Hebrews 7:20-28. Write five sentences or more comparing and contrasting the priests of the Old Testament and Jesus Christ.

# LESSON 9



## THE END TIME IS NEAR

### OBJECTIVES

1. To understand what the signs of the end times will be.
2. To understand what ungodliness is.
3. To learn how to live a godly life.

### MEMORY VERSE

"Watch therefore, and pray always that you may be counted worthy to escape all these things that will come to pass, and to stand before the Son of Man."

(Luke 21:36)

### PRAYER

1. Please give us the wisdom to understand the end times that are approaching.
2. Please help us understand how to prepare for the Lord Jesus' return, and give us the strength to spread the news to others.
3. Help us to stand firm in the Lord so that we can endure the hardships to come, and strengthen us daily so we remain steadfast in our faith.



### Overview

#### 1. The End Time Is Near

- Trials and Signs of the End Times
- Why is it taking so long?
- What should we do?

#### 2. Linking to the Ten Basic Beliefs—The Second Coming of Jesus

#### 3. Life Application—Godliness in Our Daily Lives

#### 4. Activity—Defend Yourself!



### Background Knowledge for Teachers

There are an abundance of warnings in the Bible regarding the end times. A few days before Jesus' crucifixion, He was asked to elaborate about the end times in Matthew, chapter 24. Although He never mentions the exact date, He does speak of several warning signs that will occur when the time of His Second Coming draws near.



## Reaching Out to Your Students

Straightforward instructions are the easiest for children to understand and follow. However, when it comes to spiritual instruction, “live a godly life” is probably about as vague an instruction as you can ever give them. “Deny ungodliness” is equally vague and incomprehensible. Spend time during this lesson to explain as best you can what these two concepts mean. Make sure to use common examples in their daily lives of both godly and ungodly actions. Encourage them to share their own ideas of what they believe godly and ungodly actions are. Help them to understand that although there are often so many ambiguous situations, “living a godly life” can be boiled down to the simple question of, “would God be pleased if I did this?” No matter what happens, as long as they are able to answer this question with confidence, they have nothing to fear from the tribulations that will occur during the end times.



## Opener

5 Minutes

Boys and girls, you might not watch the news with your parents, but you might have heard about all the natural disasters and wars that are happening around the world right now. Have you heard about earthquakes, hurricanes, or wars recently? [If possible, bring in news clippings of recent events in the news pertaining to natural disasters or ongoing/impending wars.]

Have any of you personally witnessed or experienced any of these events? Do you feel scared when you hear about them? True, all of these events are scary by themselves, but in this lesson, we will learn about the bigger meaning behind all of them.



## Vocabulary

**false prophets:** those who give untrue messages or teachings regarding the Bible and about God



## Bible Discovery & Spiritual Teaching

30-35 Minutes

### What Is the Second Coming?

Today, we're going to learn about a very important day. This day is the day when Jesus will come again and take His children up into heaven with Him. It will be the day we finally receive the promised eternal life. We often refer to this day as the "second coming," and the days leading up to it, the "end times."

One of our ten basic beliefs says the following: "The Lord's Second Coming will take place on the last day when He descends from heaven to judge the world: the righteous will receive eternal life, while the wicked will be eternally condemned. (Mt 25:31-34; 1 Thess 4:16-17)"

This is the very reason Jesus gave His life for us—to give us eternal life. The idea may be very strange or vague to us, though. What does it mean? Everything around us is physical. Our bodies will eventually pass away, as will the world around us. But Jesus is offering a life that will never die. Once we receive eternal life, we will never again experience death! Can you imagine living happily for the

rest of eternity?

It is for this reason that the day of Jesus' Second Coming is so important to us. But in the days leading up to His Second Coming, the “end times,” there will be many trials that we will have to undergo. Unless we overcome those trials, we won't be able to receive eternal life.

### Trials and Signs of the End Times

If the end times are a sign of Jesus' Second Coming, then how do we know that we are approaching the end times? The Bible teaches us about various events or signs that will tell us that we are very close to the end times. Let's turn to Matthew 24:3-14 and read it together.

Although He doesn't say exactly when it will happen, Jesus teaches us the signs that will mark the end times. Let's go through the verses again and list the signs together. [Teachers: Ask the students to list the signs one by one. Write them on the board as each is mentioned.]



- False Christs (v. 5)
- War/fighting nations (v. 6-7)
- Famine, pestilences, and earthquakes (v. 7)
- Persecution of Christ's followers (v. 9)
- Betrayal and hate (v. 10)
- False prophets (v. 11)
- Lawlessness and lack of love (v. 12)
- The gospel will spread to all nations (v. 14)

What a list! These are all the things that Jesus says will occur as signs of the approaching end times. This means that if we see all of these things happening, we will know that His Second Coming will be very, very soon!

#### FOR TEACHERS

Ask your students if they think they have seen any of these signs recently. Spend some time discussing them, perhaps examining a list of recent major events in the newspapers, or the attitude of non-members. **If you have the time and resources**, give the students some time to research recent major events, such as any natural disasters within the past few years, news of war or political upheaval, or even dates that have been proclaimed as the end of the world. If no computer or Internet connection is available, perhaps you can gather some recent, relevant newspapers or articles on the Internet ahead of time and bring them to class. Otherwise, continue with the lesson.

#### **Why Is It Taking So Long?**

Now that we've discussed the signs of the end times, how soon is "soon"? It seems that although we are approaching the end times, all of the signs have occurred over a very, very long period of time. Does this mean that it will still be a while until Jesus' Second Coming after all?

Let's turn to 2 Peter 3:8-9 and read it together. Although we may think that a thousand years is a very long time, to God it is equivalent to the amount of time it takes for us to blink! That's why we often say that "God's time is not our time." Having said that, it's not important for us to know the exact date and time of Jesus' second appearance. All we need to know is that, right now, the end time is near. In Matthew 24:33, Jesus tells us that the Second Coming is "at the doors"! He is ready to walk through the doors and return to the earth again at any moment!

There are things for us to learn and do while we wait!

#### **What Should We Do?**

Let's turn back to Matthew, chapter 24 and read verses 42-44. Jesus tells us that we have to watch for His coming, and "be ready." But how can we make ourselves ready?

#### *Pray for the Fullness of the Holy Spirit*

The first thing we must do to prepare ourselves is to receive the Holy Spirit. Some of us may have received it already, and others may not. We need to all pray for one another until everyone has the promised Spirit of God. But

why is the Holy Spirit so important? [Allow students to answer.] The Holy Spirit is a necessary requirement to enter heaven. If we don't have the Holy Spirit when Jesus comes, we won't be entering heaven with Him. None of us wants that to happen! But remember: even if you have the Holy Spirit already, that doesn't mean you can slack off. We need to pray until we are filled with the fullness of the Spirit, because the Spirit is not simply a ticket into heaven, it is also our guide and counselor, who can help us prepare for Jesus' Second Coming.

#### *Deny Ungodliness and Live Godly Lives*

Let's turn to a letter of Paul's and read a passage together: Titus 2:11-15.

This passage has very important teachings regarding how we should live until we are taken to heaven. Let's go through the passage and list all of the characteristics that we should strive for.

#### FOR TEACHERS

Ask the students to list the characteristics one by one, writing them on the board as they are named.

- Deny ungodliness (v. 12)
- Deny worldly lusts (v. 12)
- Live soberly (v. 12)
- Live righteously (v. 12)
- Live godly lives (v. 12)
- Look for the hope of Jesus' Second Coming (v. 13)
- Avoid lawless deeds (v. 14)
- Purify ourselves (v. 14)
- Be zealous for good works (v. 14)

Another long list! It's important to remember all of these, but today we are going to focus on two of these instructions that can be taken to encompass the rest of them: deny ungodliness, and live godly lives. But what exactly is ungodliness? And what does it mean to live a godly life?

#### FOR TEACHERS

Hand out the Bible Discovery worksheet and go through it with the students, helping where necessary. Once completed, discuss their answers to make sure the students have a thorough understanding of what ungodliness is, and what it means to live godly lives.

Being able to deny ungodliness and live godly lives makes us able to defend ourselves from sin during any trials or tribulations. As long as we can do this, we will surely be welcomed into our heavenly home when Jesus comes again, no matter what happens during the end times!

Now, before we conclude our lesson, let's all turn to our

memory verse and read it together: "Watch therefore, and pray always that you may be counted worthy to escape all these things that will come to pass, and to stand before the Son of Man." (Luke 21:36)

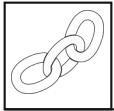

## Linking to the Ten Basic Beliefs

2-5 Minutes

### The Lord's Second Coming

The end times are a signpost indicating the second coming of Jesus. In these verses, He warns us of the tribulations to come during those times, and how we ought to conduct ourselves. We need to prepare ourselves for these tribulations and defend ourselves against sin so that when He finally comes again, we will be able to approach His throne with confidence and enter into His promised eternal life.



## Check for Understanding

5 Minutes

1. **On the second coming of Jesus, what will we receive?** We will receive our promised eternal life from Jesus.
2. **What are the end times?** The days leading up to Jesus' Second Coming.
3. **Name three signs of the end times.** False Christs; war; fighting nations; famine, pestilences, and earthquakes; persecution of Christ's followers; betrayal and hate; false prophets; lawlessness and lack of love; the spreading of the gospel to all nations.
4. **What does 2 Peter 3:8-9 say about God's time?** To God, one day is equivalent to a thousand years, and a thousand years to one day.
5. **What are three things we should do while waiting for the second coming?** Pray for the Holy Spirit/the fullness of the Spirit, deny ungodliness, and live godly lives.
6. **What are five characteristics Paul says we should strive for in Titus 2:11-15?** Deny ungodliness; deny worldly lusts; live soberly; live righteously; live godly lives; look for the hope of Jesus' Second Coming; avoid lawless deeds; purify ourselves; be zealous for good works.



## Life Application

10 Minutes

[Hand out the Life Application worksheet, and go over the introduction. Then, ask them to fill in the blanks and fill in the box. Go over the students' answers as a class if time permits.]

### Godliness in Our Daily Lives

Has there ever been a time in your life when you've completely forgotten about God? For all of us, the answer to that question would probably be an overwhelming "Yes!" In fact, it would probably be very difficult for us to count the number of times we have forgotten about God's presence. It's very easy for us to forget about Him because there are so many distractions in the world around us. On the other hand, a person who lives a godly life is a person who never forgets that He is with them!

During our lesson, we concluded that there are three common actions or characteristics of godliness. They are to...

1. Fear God
2. Love God, and
3. Seek God by being more like Him.

Try to think about some ways you can express each action in your daily life, and write your ideas in the table below. An example for each has been given to get you started. Discuss with your teacher and your classmates if you're stuck!

**Examples**

- *Never bully anyone in school, because it displeases God.*
- *Love God by loving my parents and being obedient to them.*
- *Pray every day for at least 5-10 minutes to try and draw closer to Him.*

**Activity****Defend Yourself!***10-15 Minutes*

**Objective:** To remind students to protect themselves with the armor of God.

**Materials**

- Blank paper
- Colored pencils, markers
- Construction paper (optional, for framing)
- Glue, tape (optional, for framing)

**Instructions**

1. Give each student a blank piece of paper and pencils.
2. Ask them to turn to Ephesians 6:12-17. Remind them that being godly means defending ourselves from ungodliness. In order to defend ourselves, we need to equip ourselves appropriately!
3. Have the students draw each piece of armor and label them appropriately\*. Afterwards, they may color their picture and frame it with construction paper.

\*Depending on the size of the class, you may ask them to draw the armor on large poster paper as a group instead, and hang it on the wall once the project is completed.

**HOMEWORK ANSWER KEY**

1. We will receive our promised eternal life from Jesus.
2. The days leading up to Jesus' Second Coming.
3. False Christs; war; fighting nations; famine, pestilences, and earthquakes; persecution of Christ's followers; betrayal and hate; false prophets; lawlessness and lack of love; the spreading of the gospel to all nations.
4. Answers may vary.
5. Fear God, love God, and seek God by being more like Him. Answers may vary.

## THE END TIME IS NEAR

### Part A: Deny Ungodliness

What is ungodliness? The Bible mentions it many times, but is there an exact definition? Let's turn to the following verses and see if we can get a better idea of what ungodliness means.

[Note: Although NKJV is used in the following section, you may want to bring a dictionary or go over the NIV version as well, as your students may not understand some of the words.]

1 Timothy 4:1-2

*"Now the Spirit expressly says that in latter times some will depart from the faith, giving heed to deceiving spirits and doctrines of demons, speaking lies in hypocrisy, having their own conscience seared with a hot iron."*

2 Timothy 3:2-4

*"For men will be lovers of themselves, lovers of money, boasters, proud, blasphemers, disobedient to parents, unthankful, unholy, unloving, unforgiving, slanderers, without self-control, brutal, despisers of good, traitors, headstrong, haughty, lovers of pleasure rather than lovers of God."*

1 Corinthians 6:10

*"Nor thieves, nor covetous, nor drunkards, nor revilers, nor extortioners will inherit the kingdom of God."*

### Part B: Live a Godly Life

When you read the term "godliness," how would you define it? "Denying ungodliness" and living a "godly life" are both very vague concepts, so vague that the one book that teaches us about them is one of the longest books in the world! Although the Bible doesn't give us a strict, dictionary definition for godliness, we can figure it out by looking at the many examples of godliness that the Bible offers us. Turn to the verses indicated in the table below, and fill out the chart as best you can. Consult your teacher or discuss with your neighbor if you are unsure about anything.

Bible Verse(s)	Who?	What was their attitude towards God?
1 Samuel 17:37; 26:8-11; Acts 13:22	David	<i>He had great faith in God's power and greatly feared Him. He also sought to be closer to Him.</i>
Exodus 33:15-18	Moses	<i>He sought God's presence with the Israelites, and desired to see Him face to face.</i>
Genesis 5:22, 24	Enoch	<i>He walked with God and was so close to Him that God took him before he experienced death.</i>

All three men were godly people. We can see that from their very characteristics without it being told to us. We can summarize their attitudes towards God into three basic actions or characteristics:

1. They feared God.
2. They loved God.
3. They sought to be closer to God.

Lastly, turn to the following verses and fill in the blanks.

**John 14:15-16**

*"If you love Me, keep My commandments. And I will pray the Father, and He will give you another Helper, that He may abide with you forever."*

We can then conclude from our study that to live a "godly life" means to be constantly aware of God's presence in our lives. Having godliness means to always **fear God**, **love God**, and also **seek God by being more like Him** with the help of the Holy Spirit.

**THE END TIME IS NEAR**

**Part A: Deny Ungodliness**

What is ungodliness? The Bible mentions it many times, but is there an exact definition? Let's turn to the following verses and see if we can get a better idea of what ungodliness means.

1 Timothy 4:1-2

*"Now the Spirit expressly says that in latter times some will depart from the faith, giving heed to deceiving spirits and doctrines of demons, speaking lies in hypocrisy, having their own conscience seared with a hot iron."*

2 Timothy 3:2-4

*"For men will be lovers of themselves, lovers of money, boasters, proud, blasphemers, disobedient to parents, unthankful, unholy, unloving, unforgiving, slanderers, without self-control, brutal, despisers of good, traitors, headstrong, haughty, lovers of pleasure rather than lovers of God."*

1 Corinthians 6:10

*"Nor thieves, nor covetous, nor drunkards, nor revilers, nor extortioners will inherit the kingdom of God."*

**Part B: Live a Godly Life**

When you read the term "godliness," how would you define it? "Denying ungodliness" and living a "godly life" are both very vague concepts, so vague that the one book that teaches us about them is one of the longest books in the world! Although the Bible doesn't give us a strict, dictionary definition for godliness, we can figure it out by looking at the many examples of godliness that the Bible offers us. Turn to the verses indicated in the table below, and fill out the chart as best you can. Consult your teacher or discuss with your neighbor if you are unsure about anything.



Bible Verse(s)	Who?	What was their attitude towards God?
1 Samuel 17:37; 26:8-11; Acts 13:22		



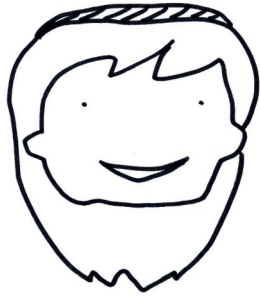

Exodus 33:15-18		
-----------------	--	--

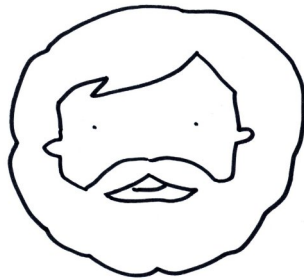

Genesis 5:22, 24		
------------------	--	--

All three men were godly people. We can see that from their very characteristics without it being told to us. We can summarize their attitudes towards God into three basic actions or characteristics:

1. They feared God.
2. They loved God.
3. They sought to be closer to God.

Lastly, turn to the following verses and fill in the blanks.

**John 14:15-16**

"If you \_\_\_\_\_ Me, \_\_\_\_\_ My \_\_\_\_\_, And I will pray the \_\_\_\_\_, and He will give you \_\_\_\_\_, that He may abide with you \_\_\_\_\_."

We can then conclude from our study that to live a "godly life" means to be constantly aware of God's presence in our lives. Having godliness means to always **fear God**, **love God**, and also **seek God by being more like Him** with the help of the Holy Spirit.

### Godliness in Our Daily Lives

Has there ever been a time in your life when you've completely forgotten about God? For all of us, the answer to that question would probably be an overwhelming "Yes!" In fact, it would probably be very difficult for us to count the number of times we have forgotten about God's presence. It's very easy for us to forget about Him because there are so many distractions in the world around us. On the other hand, a person who lives a godly life is a person who never forgets that He is with them!

# Have I completely FORGOTTEN ABOUT God!

During our lesson, we concluded that there are three common actions or characteristics of godliness. They are to...

1. \_\_\_\_\_ God,
2. \_\_\_\_\_ God, and
3. \_\_\_\_\_ God by \_\_\_\_\_.

Try to think about some ways you can express each action in your daily life, and write your ideas in the table below. An example for each has been given to get you started. Discuss with your teacher and your classmates if you're stuck!

- *Never bully anyone in school, because it displeases God.*
- *Love God by loving my parents and being obedient to them.*
- *Pray every day for at least 5-10 minutes to try and draw closer to Him.*

Once you're done, take a colored pencil, red pen, or highlighter, and pick three that you are going to try to do this week! Make sure you share your choices with your teacher.

E2 Year 2 Book 2 Lesson 9—The End Time Is Near

# Homework Assignment

Name: \_\_\_\_\_ Parent signature: \_\_\_\_\_ Date: \_\_\_\_\_

Weekly Bible Reading: \_\_\_\_\_

**Bible Reading:** Check each box when you complete that day's reading.

**Prayer:** Check each box after you pray to God that day.

	Sun	Mon	Tue	Wed	Thu	Fri	Sat
Read							
Pray							

## What I Learned from the Bible This Week

1. \_\_\_\_\_  
 \_\_\_\_\_  
 \_\_\_\_\_
2. \_\_\_\_\_  
 \_\_\_\_\_  
 \_\_\_\_\_

## Memory Verse

Please write down this week's memory verse. (Luke 21:36)

\_\_\_\_\_

## Short Answer

1. On the second coming of Jesus, what will we receive?
2. What are the end times?
3. Name three signs of the end times.
4. Explain what ungodliness means, and give an example.
5. Name three actions or characteristics that summarize what it means to live a godly life. Name three examples of how you can live a godly life at home.

# LESSON 10

## THE PARABLE OF THE TEN VIRGINS

### OBJECTIVES

1. To remind students about the importance of being responsible for our own spirituality.
2. To understand the importance of being filled with the Holy Spirit and spiritually prepared for the Lord's Second Coming.
3. To understand what it means to stay alert and watchful.

### MEMORY VERSE

"Watch therefore, for you know neither the day nor the hour in which the Son of Man is coming."

(Matthew 25:13)

### PRAYER

1. We thank God for gathering us here so that we can worship and learn more about His words.
2. Lord, please help us to be wise in all that we do.
3. Today, we'll learn about the Lord's Second Coming. Please grant us the wisdom and strength to be prepared for your second coming.
4. May God help us focus on this lesson and apply its teachings to our lives.



### Overview

1. **The Parable of the Ten Virgins** (Mt 25:1-13)
  - The Wise and the Foolish
  - The Second Coming of Christ
2. **Linking to the Ten Basic Beliefs**—The Lord's Second Coming
3. **Life Application**
  - Being Responsible for My Spirituality
  - Fill Me, Holy Spirit
4. **Activity**—Oil Jar



### Background Knowledge for Teachers

#### The Ten Virgins

In Jesus' time, it was a custom among the Jews for the bridegroom to come at night to the bride's house, where her virgins—sometimes translated as bridesmaids—attended her. When the bridegroom's approach was announced, these women went outside with lamps to light his way into the house for the feast and celebration.

#### The Bridegroom

In the Bible, the image of a wedding is often used to portray the coming of the Lord (see Isa 62:5; Mt 22:1–14). Alongside the custom of bridesmaids lighting his way, there would also be an announcement of the bridegroom's approach to the bride's house. The weddings usually began in the evening and the lamps would be lit by sunset. In the parable, midnight was an unusual time for his approach, and definitely later than the ten virgins would have expected to wait.

#### Vessels

The vessels mentioned in the parable were just containers for storing extra oil. They were most likely made of clay.

#### Lamps

The oil lamps used by the Jews in Jesus' day were called Herodian lamps, named after King Herod. These lamps enabled people to bring light with them wherever they went. The lamp's body was made of clay shaped on a potter's wheel, while the handle was fashioned by hand before being attached. The spout, or nozzle, inside which a wick of flax fibers or a rush stem was placed, was made from a mold. The lamp would be filled with olive oil, and the wick, after absorbing the oil, would be lit.

**Oil**

Olives are first soaked in water to clean them and to get rid of their bitterness. They are then crushed to extract their oil. Olive oil, produced throughout the Mediterranean region, had multiple uses back in those times: it was eaten as a food or condiment, made into cooking oil, placed on wounds, used in cosmetics and soaps, and, of course, made into fuel for lamps.



## Reaching Out to Your Students

It's important for the students to understand, as early as possible, that they must be responsible for their own faith and spirituality. Most likely, at this age, they are brought to church and services by their parents or guardians. But, it's important that your students understand that no one is able to share their spirituality (the oil) with others. Their faith must be their own. Thus, the responsibility for having oil in our personal lamps is up to each of us. No one else can fill it for us.

The wise virgins in this parable were not mean or selfish when they refused give oil to the foolish ones. In a spiritual sense, the oil in the parable represents the Holy Spirit. It represents the kind of oil needed by all of us to light up the darkness and illuminate the way. This kind of oil cannot be shared. It is accumulated by living righteously, loving those around us, loving God, and above all, following God's word as closely as can be done. The greatest challenge is that as your students grow older, learn to be independent, and make their own decisions, will they be able to strengthen their faith and pursue God?



## Opener

*5 Minutes*

Pretend that we are going on a trip. What would we need to do to prepare? What should we take with us for the trip? Try to think of one thing that you will bring along.

[Write on the board, "For our trip, we're going to take..." and list your own item first. Then, go around the room and continue adding the items each student names. You may circle around the room an additional one or two more times, if you'd like.]

What a long list! And there are probably so many more things that we could add to it. For any trip we take, we have to spend time packing. If I told you that we were going to go on this trip today, after church, you'd probably protest and ask to go home and pack first. This is because you want to prepare yourselves.

Preparation is very important for many things in our lives. What are some things we might need to prepare ourselves for in our everyday lives, besides going on a trip? [Allow students to give you ideas. Some examples might be tests at school, projects, meals, or family outings.]

Well, we've certainly named a lot of things in our daily lives that require preparation. Did you know that our spiritual lives are no different? Everything we do, spiritually, also requires preparation, just like preparing for a meal or a trip.

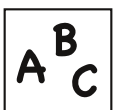

## Vocabulary

**virgin:** a person who has never had a physical union with another person  
**bridegroom:** the groom, or a man on his wedding day



## Bible Discovery & Spiritual Teaching

30-35 Minutes

Today we're going to learn about the Parable of the Ten Virgins, and about how some of them prepared themselves, while the others did not. Let's open our Bibles to Matthew 25.

Let's begin our story by reading verses 1-4. In Jewish weddings, the bridegroom would approach the bride's house in the evening. When he approached, there would be a great announcement, and the bridesmaids would light the way for him. In biblical times, since they had no electricity, they had to use oil lamps made of clay. They would light them just after sunset and wait. Since the lamps required fuel, they would also carry vessels, which contained additional oil for the lamps.

In the verses we just read, five of the virgins were wise and carried vessels with extra oil, while the other five were foolish and did not. Why do you think they needed extra oil? (In case they need to be outside longer than expected.)

Let's continue to read verses 5-9. The bridegroom finally arrived, but at a much, much later hour than expected! Normally, he would have arrived in the evening, but in this parable, he arrived well after midnight. Since it was so late, the virgins fell asleep while they waited, and didn't awaken until he was finally announced.

When they awoke, the virgins prepared their lamps by trimming the wicks. Do you know why they had to do this? Just like regular candles today, their lamps had a wick, but instead of string it was made of flax fibers or rushes. Once these were soaked in the oil, they would burn when lit. But after being lit for a while, the wick would turn black, and the light wouldn't be as bright. So in order to make it bright again, they had to blow out the candle, trim off the burnt part, add more oil to the lamp, and then re-light the wick.

In the parable, though, the five foolish virgins had no extra oil to add to their lamps. This meant that their lights would go out before the bridegroom approached! How would they light his way with no light? So they asked the other five for extra oil, but they refused, because if they shared their oil, then that meant their own lamps would also go out, and none of them would be able to light his way!

Let's finish the story and read verses 10-13. While the foolish virgins were buying oil, the bridegroom finally arrived, and those who were ready to greet him went with him into the house to enjoy the wedding banquet. But those who were unprepared and had to go buy oil were

locked out of the house.

### The Lord's Second Coming

Let's examine this parable closely and study what it means. First of all, what is the parable talking about? In verse 1, Jesus says, "The kingdom of heaven shall be likened to ten virgins who took their lamps and went out to meet the bridegroom." This parable is supposed to be a teaching about Jesus' Second Coming, which we learned about last week. Does anyone remember the purpose of Jesus' Second Coming? (To gather His elect, destroy the world, judge mankind, and to welcome us into our eternal home.)

Now that we know what the parable is about, we can see what each element represents.

- The bridegroom represents Jesus Christ.
- The ten virgins represent the believers of the church.
- The oil represents the Holy Spirit.
- The marriage represents Jesus taking His believers into heaven.
- The lamp represents us, the chosen vessels of God.

At first glance, we can see that all the ten virgins appear to be the same:

- All were invited to the banquet and were planning to attend.
- All had gone out to wait for the bridegroom.
- All of them had their lamps with them.
- All of them wanted to see the bridegroom and attend the banquet.
- All were in the right place at the right time for the right reason.
- All had their lamps lit while waiting.
- All fell asleep while waiting for the bridegroom, and then were awakened by the midnight cry.
- All ten virgins got up to prepare their lamps.

Despite all of these similarities, five made it to the banquet and five did not. What was the difference? The five wise virgins had extra oil. That's correct, five of them had extra oil, and five did not. This means that five of them had prepared themselves for the possibility that the bridegroom would be late, while the other five did not bother.

#### FOR TEACHERS

Hand out the Bible Discovery worksheet to the students, and have them fill it out at this point.



**Do you think it was mean of the wise virgins to refuse to share their oil? Why or why not?**

It might seem a little bit mean to us. If they had shared their oil, perhaps they all could have made it. On the other hand, if they shared their oil, it is also very likely that none of them would have made it. They were looking out for themselves, because they had waited so long for the bridegroom to come and did not want to be locked out of the banquet.

In the same way the lamps of the virgins lit the streets, we, the vessels of God, are lamps that light the world with God's Word. Our oil, or fuel, is the Holy Spirit, and as

God's chosen vessels, we each need to fill ourselves with it. This kind of fuel is impossible to share with others. Everyone needs to fill their own lamps, and unless we prepare ourselves, we will be locked out of the kingdom of God.

This is why in verse 13, Jesus warns us, "Watch therefore, for you know neither the day nor the hour in which the Son of Man is coming." We absolutely must prepare ourselves by being filled with the Holy Spirit so that we can be ready for Him whenever He approaches, no matter when it is. As long as we are prepared, we can be ready to greet Him at any time, just like the five wise virgins.



## Linking to the Ten Basic Beliefs

*2-5 Minutes*

### The Lord's Second Coming

Not even the angels or Jesus Himself knows when the second coming will be. It could be the next hour, the next year, or the next millennia. From the parable of the ten virgins, we learned that five of the virgins had the foresight to realize that they did not know when the bridegroom would approach, while the other five did not, and ended up running out of oil. We absolutely must prepare ourselves, and not just for the coming of the Lord—we must prepare ourselves however long it may take. This means filling ourselves with the Holy Spirit and constantly keeping our lamps burning bright for as long as it is necessary.



## Check for Understanding

*5 Minutes*

1. **The ten virgins were going to attend what sort of gathering?** A wedding.
2. **Who does the bridegroom represent?** Jesus Christ.
3. **Who do the ten virgins represent?** The chosen vessels of God.
4. **Why did the virgins fall asleep?** The bridegroom came much later than expected.
5. **Where were the five foolish virgins when the bridegroom arrived?** Looking for oil to purchase.
6. **What does the oil represent?** The Holy Spirit.
7. **What must we do to prepare for the second coming of Jesus?** Fill ourselves with the Holy Spirit and keep our lamps burning until He arrives so that we can be ready to greet Him.



## Life Application

*10 Minutes*

### 1. Being Responsible for My Spirituality

**Objective:** To learn the importance of being responsible for our own spirituality.

[Hand out Life Application Worksheet #1 to the students and refer to Teacher Version for instructions.]

### 2. Fill Me, Holy Spirit

**Objective:** To understand the importance of being filled with the Holy Spirit and spiritually prepared for the Lord's Second Coming.

[Hand out Life Application Worksheet #2 and guide the students to fill it out. First, go over the introduction with the students, and then ask them to fill in the box with the verse. Secondly, ask students to draw a line on the lamp picture and fill in the blanks. Lastly, discuss the scenarios with the students. There are no concrete answers, so ask the students to share their thoughts.]



## Activity

### Oil Jar

10-15 Minutes

**Objective:** To remind students about filling their own lamps with oil.

#### Materials

- Small jars and lids with the labels removed (baby food or jam jars work best), one per student
- Decorations appropriate for glass (e.g., stickers, permanent markers, glitter, glass paint, etc.)
- 1-2" piece of cotton string, or small piece of candle wick
- Masking tape
- A small piece of decorative fabric
- Fabric shears, optional
- Thin ribbon, optional
- White glue
- Olive oil

#### Instructions

1. Give one jar each to the students and allow them to decorate it.
2. Tape the "wick" to the top of the jar lid with a small piece of tape, making sure that the wick stands up in the center. (If your wick needs help standing up, coat it in glue and suspend the lid upside down so that it can dry in place.)
3. Cut the fabric to fit the jar lid exactly. Use fabric shears, if available, to prevent fraying. Then, cut a small hole in the center. (It helps to fold the circle in half so you can cut a little notch easily.)
4. Thread the "wick" through the hole in the fabric, and then glue the fabric onto the jar lid. Allow time for it to dry.
5. A thin ribbon can be glued around the jar lid rim for a finishing look, if desired.
6. Let everything dry thoroughly. You may need to help the students fix some final loose pieces with white glue or a glue gun.
7. Fill the jar with the olive oil.
8. Conclude the activity by reminding the students to keep their jars full of oil by always pursuing after the fullness of the Holy Spirit.

#### HOMEWORK ANSWER KEY

1. midnight
2. oil
3. fell asleep
4. looking for oil
5. The five wise virgins were unable to share their oil with the foolish virgins because there was not enough oil for all of them to share. This parable teaches us that we are responsible for our own spirituality. It is up to us to fill ourselves with the Holy Spirit.

**Who Was Wise? Who Was Foolish?**

**Instructions:** Write the following statements in the correct side of the chart below.

1. Went to find oil
2. Had extra oil in their lamps
3. Didn't have enough oil to share
4. Bridegroom didn't know them
5. Ran out of oil
6. Knocked on the door
7. Were prepared and ready for the marriage
8. Went with the bridegroom

Which Were Wise?	Which Were Foolish?
<ul style="list-style-type: none"> <li>• <i>Had extra oil in their lamps</i></li> <li>• <i>Didn't have enough oil to share</i></li> <li>• <i>Went with the bridegroom</i></li> <li>• <i>Were prepared and ready for the marriage</i></li> </ul>	<ul style="list-style-type: none"> <li>• <i>Went to find oil</i></li> <li>• <i>Bridegroom didn't know them</i></li> <li>• <i>Ran out of oil</i></li> <li>• <i>Knocked on the door</i></li> </ul>

**Instructions:** Fill in the blanks below.

1. The bridegroom represents Jesus Christ.
2. The ten virgins represent believers or people of the world.
3. The oil represents the Holy Spirit.
4. The marriage represents Jesus taking His believers to heaven.
5. The lamps represent the chosen vessels of God.

**Instructions:** Luke 12:35-40 teaches us some very important things about the second coming of Christ. Turn to the passage and fill in the blanks below.

- v. 35 - "Let your waist be girded and your lamps burning."
- v. 36 - "You yourselves be like men who wait for their master, when he will return from the wedding, that when he comes and knocks they may open to him immediately."
- v. 37 - "Blessed are those servants whom the master, when he comes, will find watching."
- v. 38 - "And if he should come in the second watch, or come in the third watch, and find them so, blessed are those servants."
- v. 39 - "But know this, that if the master of the house had known what hour the thief would come, he would have watched and not allowed his house to be broken into."
- v. 40 - "Therefore you also be ready, for the Son of Man is coming at an hour you do not expect."

Just as the servants have to always be ready for the master to appear at any time, we also have to be ready to receive Jesus when He comes again. This means that we have to **prepare** ourselves and **watch diligently** for Him. The moment we slack off and forget about Him, or decide that there are other things that we could be doing, He may appear. And, like the bridegroom did with the five foolish virgins, if He appears when we aren't ready, then we will be barred from the kingdom of heaven!

But how are we supposed to prepare ourselves? Being prepared means being diligent towards God in our daily lives, and living a life according to God's Word.

**Instructions:** Read the verses below and write down what kind of actions we are supposed to take in order to prepare ourselves. The first has been given as an example to help you along.

Romans 6:2: We must admit our sins and repent.

Romans 12:2: We must keep ourselves separate from the world.

Matthew 5:44: Love everyone, even our enemies.

Psalm 19:14: Be careful of our speech; speak things acceptable to God.

## Being Responsible for My Spirituality

**Objective:** To learn the importance of being responsible for our own spirituality.

### What Is Spirituality?

First of all, what exactly is "spirituality"? Our spirituality is our **connection with God**. The greater your spirituality, the deeper your connection with God. However, it isn't something that grows by itself—we have to **actively seek God in order to make it grow**. It's very easy for us to think of attending church as a formality, a custom, or even a habit. But attending services, learning about God in RE classes, and even taking part in fellowships are all things we do in order to make our spirituality grow.

Right now, you probably attend church because your parents bring you every week. But, just like the five wise virgins in the parable, we cannot rely on others. We have to fill our lamps ourselves. This means that **we must be responsible for our own spirituality**.

Read the following scenarios and Bible verses, and then write down how we can develop our spirituality.

### Scenario #1

Cynthia is almost finished with her school year and she's been very busy with her final science project, tests, and her upcoming piano recital. Every day when she gets home from school, she works hard until bedtime to prepare for all those things. Before she goes to bed, she usually feels quite tired. However, she always remembers that she must spend time with God. So, before sleeping, she takes out her Bible and reads. As she reads, she also likes to take notes, especially on questions that she has about the passages. She then prays and goes to bed.

Psalm 1:2 - "But his delight is in the law of the Lord, and in His law he meditates day and night."

We can develop our spirituality by...*Meditating on God's Word and trying to keep His words in our heart.*

### Scenario #2

Ethan is a very loving person and frequently has guests over his house. He often holds fellowships and Bible studies at his house, and many out-of-town guests stay at his home, too.

One of his frequent guests, Tyler, always rings the doorbell several times in a row. All of the other guests only ring it once and Ethan is there to open the door in only a few seconds. Tyler's actions make Ethan a little angry because the incessant ringing annoys him and disturbs the guests that have already arrived. However, instead of saying angry words to Tyler, Ethan waits to think about what to say and how to say it, before telling Tyler what he thinks.

Psalm 34:13 - "Keep your tongue from evil, and your lips from speaking deceit."

We can develop our spirituality by...*Avoiding angry words, and speaking things that would please God instead.*

### Scenario #3

During lunchtime at school, Kimberly would always get her books knocked off the table by Lisa. They used to be friends back in first grade, but for some reason, Lisa just didn't like Kimberly anymore. However, Kimberly never did or said anything back to Lisa whenever this happened. She simply picked up her books and continued eating her lunch.

One afternoon, after school, Kimberly saw Lisa walking home ahead of her. She kept her distance so that Lisa won't do anything to her. But then she saw Lisa trip and scratch herself on the sidewalk. Even from a distance, Kimberly could see that it really hurt, so she ran over to see if Lisa was okay. When she got there, she saw that Lisa was bleeding a little, so she washed the scratch with water from her bottle and gives Lisa a Band-Aid from her bag. Lisa couldn't believe it; she had bullied Kimberly every day at lunch, but instead of treating her like an enemy, Kimberly helped her when she was hurt.

Matthew 5:44 - "But I say to you, love your enemies, bless those who curse you, do good to those who hate you, and pray for those who spitefully use you and persecute you."

We can develop our spirituality by...*Being kind to those who are mean to us, and not retaliating to those who mistreat us.*

**Who was wise? Who was foolish?**

**Instructions:** Write the following statements in the correct side of the chart below.

1. Went to find oil
2. Had extra oil in their lamps
3. Didn't have enough oil to share
4. Bridegroom didn't know them
5. Ran out of oil
6. Knocked on the door
7. Were prepared and ready for the marriage
8. Went with the bridegroom

Which Were Wise?	Which Were Foolish?

**Instructions:** Fill in the blanks below.

1. The bridegroom represents \_\_\_\_\_.
2. The \_\_\_\_\_ represent believers or people of the world.
3. The oil represents the \_\_\_\_\_.
4. The \_\_\_\_\_ represents Jesus taking His believers to heaven.
5. The \_\_\_\_\_ represent the chosen vessels of God.

**Instructions:** Luke 12:35-40 teaches us some very important things about the second coming of Christ. Turn to the passage and fill in the blanks below.

- v. 35 - "Let your \_\_\_\_\_ be girded and your lamps \_\_\_\_\_."
- v. 36 - "You yourselves be like men who \_\_\_\_\_ for their \_\_\_\_\_, when he will \_\_\_\_\_ from the wedding, that when he comes and knocks they may \_\_\_\_\_ to him \_\_\_\_\_."
- v. 37 - "\_\_\_\_\_ are those servants whom the master, when he \_\_\_\_\_, will find \_\_\_\_\_."
- v. 38 - "And if he should come in the \_\_\_\_\_ watch, or come in the \_\_\_\_\_ watch, and find them so, \_\_\_\_\_ are those \_\_\_\_\_."
- v. 39 - "But know this, that if the master of the house had \_\_\_\_\_ what \_\_\_\_\_ the \_\_\_\_\_ would come, he would have \_\_\_\_\_ and not allowed his house to be \_\_\_\_\_ into."
- v. 40 - "Therefore you also be \_\_\_\_\_, for the \_\_\_\_\_ of \_\_\_\_\_ is coming at an \_\_\_\_\_ you do not \_\_\_\_\_."



Just as the servants have to always be ready for the master to appear at any time, we also have to be ready to receive Jesus when He comes again. This means that we have to **prepare** ourselves and **watch diligently** for Him. The moment we slack off and forget about Him, or decide that there are other things that we could be doing, He may appear. And, like the bridegroom did with the five foolish virgins, if He appears when we aren't ready, then we will be barred from the kingdom of heaven!

But how are we supposed to prepare ourselves? Being prepared means being diligent towards God in our daily lives, and living a life according to God's Word.

**Instructions:** Read the verses below and write down what kind of actions we are supposed to take in order to prepare ourselves. The first has been given as an example to help you along.

Romans 6:2: We must admit our sins and repent.

Romans 12:2: \_\_\_\_\_

Matthew 5:44: \_\_\_\_\_

Psalms 19:14: \_\_\_\_\_



## Being Responsible for My Spirituality

### What Is Spirituality?

First of all, what exactly is "spirituality"? Our spirituality is our **connection with God**. The greater your spirituality, the deeper your connection with God. However, it isn't something that grows by itself—we have to **actively seek God in order to make it grow**. It's very easy for us to think of attending church as a formality, a custom, or even a habit. But attending services, learning about God in RE classes, and even taking part in fellowships are all things we do in order to make our spirituality grow.

Right now, you probably attend church because your parents bring you every week. But, just like the five wise virgins in the parable, we cannot rely on others. We have to fill our lamps ourselves. This means that **we must be responsible for our own spirituality**.

Read the following scenarios and Bible verses, and then write down how we can develop our spirituality.

### Scenario #1

Cynthia is almost finished with her school year and she's been very busy with her final science project, tests, and her upcoming piano recital. Every day when she gets home from school, she works hard until bedtime to prepare for all those things. Before she goes to bed, she usually feels quite tired. However, she always remembers that she must spend time with God. So, before sleeping, she takes out her Bible and reads. As she reads, she also likes to take notes, especially on questions that she has about the passages. She then prays and goes to bed.

Psalm 1:2 - "But his delight is in the law of the Lord, and in His law he meditates day and night."



We can develop our spirituality by \_\_\_\_\_

---

**Scenario #2**

Ethan is a very loving person and frequently has guests over his house. He often holds fellowships and Bible studies at his house, and many out-of-town guests stay at his home, too.

One of his frequent guests, Tyler, always rings the doorbell several times in a row. All of the other guests only ring it once and Ethan is there to open the door in only a few seconds. Tyler's actions make Ethan a little angry because the incessant ringing annoys him and disturbs the guests that have already arrived. However, instead of saying angry words to Tyler, Ethan waits to think about what to say and how to say it, before telling Tyler what he thinks.

Psalm 34:13 - "Keep your tongue from evil, and your lips from speaking deceit."

We can develop our spirituality by \_\_\_\_\_

---

**Scenario #3**

During lunchtime at school, Kimberly would always get her books knocked off the table by Lisa. They used to be friends back in first grade, but for some reason, Lisa just didn't like Kimberly anymore. However, Kimberly never did or said anything back to Lisa whenever this happened. She simply picked up her books and continued eating her lunch.

One afternoon, after school, Kimberly saw Lisa walking home ahead of her. She kept her distance so that Lisa won't do anything to her. But then she saw Lisa trip and scratch herself on the sidewalk. Even from a distance, Kimberly could see that it really hurt, so she ran over to see if Lisa was okay. When she got there, she saw that Lisa was bleeding a little, so she washed the scratch with water from her bottle and gives Lisa a Band-Aid from her bag. Lisa couldn't believe it; she had bullied Kimberly every day at lunch, but instead of treating her like an enemy, Kimberly helped her when she was hurt.



Matthew 5:44 - "But I say to you, love your enemies, bless those who curse you, do good to those who hate you, and pray for those who spitefully use you and persecute you."

We can develop our spirituality by \_\_\_\_\_

---

### Fill Me, Holy Spirit

**Objective:** To understand the importance of being filled with the Holy Spirit and spiritually prepared for the Lord's Second Coming.

#### What does it mean to be filled with the Holy Spirit?

To be filled with the Spirit means to allow the Holy Spirit to control us rather than giving in to the world. When we try to live a more holy life, we follow the guidance of the Holy Spirit and make choices according to God's Word.

#### What does it mean to receive power with the Holy Spirit?

Just before Jesus went up to heaven, He said, "You shall receive power when the Holy Spirit has come upon you" (Acts 1:8).

Have you ever seen someone who's drunk? You immediately know they are drunk because of the characteristics they display—they can't speak properly, can't walk properly, are slow to act, and make poor decisions.

In very much the same way, it's very easy to see when someone is filled with the Holy Spirit. What kind of characteristics does this person show? Read Galatians 5:22-23 and list them below:

All of these are characteristics of a Christian. This means that in order to truly be a Christian, one must be filled with the power of the Holy Spirit.

Reflect on your level of oil. Are you filled with the Holy Spirit? How much have you prepared? Has the flame died out? Whether or not you have the Holy Spirit, think about how you are keeping up with your spirituality: Are you reading the Bible daily? Praying? Obeying your parents? Following God's words?

Draw a line in the lamp that you think shows the level of oil you have right now, and then fill in the blanks.



#### Time I Spend Adding Oil...

Through prayer:

\_\_\_\_\_ minutes per day

Through Bible reading:

\_\_\_\_\_ minutes per day

**On the next page, read each scenario and discuss the questions that follow.**

1. During prayer time, Patrick always has a hard time concentrating and staying focused. He constantly feels the urge to open his eyes and look around a little bit. During the longer prayers, he checks the clock every few minutes.

**Is Patrick filled with the Holy Spirit?**

**What should he be doing instead?**

2. Arthur just finished praying during the RE prayer at church. After heading back into his E2 classroom, he noticed that his pencil box was on the floor with everything, its contents scattered all over the floor. Roger had been sitting next to him, and he knew that he was a clumsy person. When Roger came back in, Arthur asked if he did it. Roger replied saying that it was possible that he knocked it over when he left the classroom. Arthur got angry with him, called him a "clumsy pig," and decided to push all of Roger's things onto the floor, too. They both started to argue.

**Is Arthur filled with the Holy Spirit?**

**What should he have done instead?**

3. Craig has been best friends with Philip, Randy, and Juan for over seven years. However, in recent years, his friends have changed. They like to go to parties, and their speech is littered with many inappropriate words. They often invite Craig to hang out and play video games on Saturdays. It is hard for Craig to resist, as these are his childhood friends and he enjoys their company. But, he is even closer friends with God and watchful about his spirituality. Eventually, his friends change so much it seems like he doesn't know them anymore, and they drift apart.

**Is Craig filled with the Holy Spirit?**

**Should he have done anything different?**

E2 Year 2 Book 2 Lesson 10—The Parable of the Ten Virgins

# Homework Assignment

Name: \_\_\_\_\_ Parent signature: \_\_\_\_\_ Date: \_\_\_\_\_

Weekly Bible Reading: \_\_\_\_\_

**Bible Reading:** Check each box when you complete that day's reading.

**Prayer:** Check each box after you pray to God that day.

	Sun	Mon	Tue	Wed	Thu	Fri	Sat
Read							
Pray							

## What I Learned from the Bible This Week

1. \_\_\_\_\_  
 \_\_\_\_\_  
 \_\_\_\_\_
2. \_\_\_\_\_  
 \_\_\_\_\_  
 \_\_\_\_\_

## Memory Verse

Please write down this week's memory verse. **(Matthew 25:13)**

\_\_\_\_\_

### Fill In the Blank

1. The bridegroom arrived late, after \_\_\_\_\_.
2. The five wise virgins brought extra \_\_\_\_\_.
3. While waiting for the bridegroom to arrive, the ten virgins \_\_\_\_\_.
4. When the bridegroom arrived, the five foolish virgins were \_\_\_\_\_.

### Short Answer

5. Why were the five wise virgins unable to share with the foolish ones? What does this mean for us today?



# LESSON 11

## THE PARABLE OF THE GREAT BANQUET

### OBJECTIVES

1. To learn about the invitation God has given us to join Him in His heavenly kingdom.
2. To understand the importance of accepting God's invitation.
3. To understand that if we are not careful, we may decline His invitation and disappoint God.

### MEMORY VERSE

"Behold, I stand at the door and knock. If anyone hears My voice and opens the door, I will come in to him and dine with him, and he with Me."

(Revelation 3:20)

### PRAYER

1. We thank God for providing us this Sabbath day so that we can worship and learn more about His words.
2. Lord, we thank You for guiding us through this past week and ask You to continue to guide us through the coming week.
3. Please help us to understand the importance of the invitation You have extended to us, and how we can accept it.
4. Please also help us to focus on this lesson and apply its teachings to our lives.



### Overview

#### 1. The Parable of the Great Supper

- Jews and Gentiles
- The Heavenly Kingdom
- Acceptance and Rejection

#### 2. Linking to the Ten Basic Beliefs—Salvation is given by grace

#### 3. Life Application

- "You're Invited!"
- "Excuses, Excuses, Excuses"

#### 4. Activity—Invitation Cards



### Background Knowledge for Teachers

#### The Banquet of the Heavenly Kingdom

During Jesus' time, the idea that Gentiles might be able to inherit the promised heavenly kingdom would have shocked and appalled many Jews. Their entire belief is based on the idea that they are a chosen people due to their direct lineage from Abraham. In the parable, though, those who were invited gave excuses and refused the invitation, making a mockery of the host, and implying the banquet's lack of importance in their lives. Jesus warned those who listened that, although they may have been invited, refusing meant that they would not even be able to have a taste of the banquet, and others would take their place—even Gentiles, who were not initially invited. The Jews' refusal to believe in Him was but one example of one who declined the invitation.

#### The Sabbath Banquet

Although we reach for the ultimate "banquet"—the heavenly kingdom—and strive towards it, there is an additional banquet that we are invited to every week: Sabbath day. The simple act of attending church is a banquet for our spirit—we are given spiritual food and water so that our faith may grow. The repetition of this invitation, however, often leads us to take it lightly, and we may begin to prioritize other things in our lives. Work, family, or other responsibilities are all different excuses we may give. But whatever excuses we may think of, they are never good enough reasons to refuse to spend time with God. At the end of the day, whether we prioritize God or our daily lives is tested in whether we refuse or accept this invitation.



## Reaching Out to Your Students

It is easy for your students to find excuses not to attend Sabbath service at church. There are school assignments that require their attention, sports matches, tournaments, events and birthday parties to attend, cartoons to watch, and the list goes on. Although your students are probably compelled to attend by the encouragement of their parents, when they grow older and no longer have such parental influences, will they continue to attend Sabbath services?

Today's lesson will help your students understand the importance of accepting and taking up the invitation that God has given to all of His children. Discuss with your students the reasons we attend church, and the reasons we often make excuses not to attend. Be sure to remind them that although it is completely normal to want to skip church sometimes, especially when our faith is weak, it doesn't mean that we should allow ourselves do it. In fact, the days we make excuses to avoid church are days we need to be especially careful that we do not sin. Help your students come up with ways to strengthen their faith when it comes to these feelings.



## Opener

*5 Minutes*

Have you ever invited your friends to a party, but they said that they couldn't come? Do you remember what your friends said when they couldn't come?

[Ask students to share some excuses they have heard or even used. Then, give some examples of excuses that might be commonly given. "I have to finish my homework." "Your house is too far." "I don't have time that day." Ask students how they feel when people give them excuses and decline their invitations.]

Suppose that you invited me to your house and I said I couldn't come because I lost a button from my pants. Sounds like a silly excuse, doesn't it? What are some funny excuses you've heard or even used before in different situations?

In our Bible story, we'll hear the excuses people used that might sound a little silly.

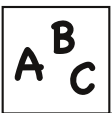

## Vocabulary

**lame:** a person who is unable to move or has extreme difficulty moving on their own, especially walking  
**crippled:** person or animal that is partially disabled or unable to use one or more of their legs or arms



## Bible Discovery & Spiritual Teaching

*30-35 Minutes*

### FOR TEACHERS

For the first Bible Discovery worksheet, students will be illustrating the story using panels and captioning the panels. Eight panels have been given, but you may add or remove as many as you'd like, depending on how long you think it will take your students to read the story and to illustrate it. Encourage them to keep their pictures simple.

Last week, we learned about being prepared for the Lord's Second Coming, just like the five wise virgins who brought extra oil for their lamps. This week, we're going to continue learning about Jesus' salvation through a different parable in the Bible.

Let's turn to Luke 14:15-24 and read it together.

What do you think of the people who made all of the excuses? Don't you think the excuses were a little bit silly? What about the man who held the feast? He must have been pretty hurt when they gave all of their excuses.

Have you ever been invited to a birthday party, or perhaps a wedding? If you were close friends with the person who invited you, then you would naturally really, really want to go, right? On the other hand, if it's someone you don't like, then you would really not want to go and would think of excuses to avoid it.

It's the same case in this story. The man who invited all those people was clearly rejected by them—they prioritized other things over him, and decided that the banquet was an unimportant event that they didn't want to or need to attend.

#### FOR TEACHERS

Hand out Bible Discovery Worksheet #1 and help the students summarize the story in eight or less panels.

Below are suggestions for captions that the students may want to use for their pictures. Encourage them to think of their own if they'd like. Let them be as creative as they can! Just remember that the purpose is to help them remember and understand the parable. For example, drawing a picture of food may help them remember that it was a banquet, or drawing their idea of heaven may remind them that the banquet represents God's kingdom.

#### Sample Captions

1. There was a man who hosted a great banquet and invited many people.
2. When the day of the banquet arrived, he sent his servants out to fetch them.
3. But when the servants told them about the banquet, they all gave excuses not to come!
4. The master was very angry when he heard about this, so he said, "Go invite the poor, lame, and the blind from the streets instead!"
5. The servants did as he said, but there was still space at the banquet.
6. So, the master told his servants to go out even further and find more people to fill the house!
7. He told the servants, "None of those I invited will taste my banquet!"
8. God has invited us to His banquet. But are we making excuses not to come?

### Jews and Gentiles

There are several teachings that we can draw from this parable. First, let's learn what it meant for the Jews during Jesus' time.

Try to recall what you know about the Israelites in Old Testament times. Do you remember the story about the Israelites and the golden calf that they made and worshipped? From when they were first rescued from Egypt, the Israelites disobeyed God many times, and often rebelled or rejected Him. They even asked for a king when they should have realized that the only ruler they needed was God Himself!

Later, in New Testament times, the Jews followed the Mosaic laws very closely, and even had appointed "teachers of the law" who dedicated their lives to examining God's laws. But unfortunately, they became so focused on the *words* of the law that they didn't understand the *spirit* of the law—to love God, and to love men. It was because of this that they could not understand why Jesus was the Messiah. They expected someone else—someone who was more like a king, who would lead them as a worldly nation and rescue them from oppression

under Roman rule. But what they didn't realize was that Jesus would lead them into a *spiritual* kingdom, not a physical one. This is why they rejected Jesus.

In the parable, there were people who were initially invited by the host. However, these people ended up making excuses and refused to attend. The Jews, too, were initially God's chosen nation. They were supposed to be His special people who would gain a special status in the heavenly kingdom. But they rejected God and refused to believe that Jesus was the Messiah.

In the parable, what did the host order his servants to do when they reported the excuses the invited gave? [Allow students to answer.] That's correct, he ordered them to go out and invite anyone they could find: the lame, the crippled, those on the street, and even those outside the city. Everyone was invited **except** those who were initially given the invitation! In much the same way, we who are non-Jewish peoples—or Gentiles—were given an invitation into God's kingdom because those originally invited rejected Him. We need to value this invitation and work hard to be ready for the time to come, when His servants run out to tell us, "The banquet is ready!"

### The Heavenly Kingdom

Although we've learned that we have received an invitation to God's kingdom, what exactly does this mean? Well, in the last lesson, we learned about this too: we have all been invited to receive salvation and live with God for eternity. The banquet in the parable refers to this wonderful gift. It's hard to imagine this kind of gift, though, so let's learn a little more about what the heavenly kingdom will be like.

#### FOR TEACHERS

Hand out Bible Discovery Worksheet #2 and help the students refer to the Bible to complete it.

#### Answers

1. paradise
2. joy, Holy Spirit
3. dwell with them
4. tear, death, pain
5. gold
6. curse
7. paradise

Heaven must be pretty amazing according to these verses! Can you even imagine living forever, much less living joyfully every single day? Knowing this, do you think you would decline God's invitation?

### Acceptance and Rejection

In the parable, the people who were first invited rejected the invitation by giving excuses. But today, how do we reject God? We would not say, "No, I don't want to go to

heaven.” But even if we don’t decline verbally, we still decline through our actions.

Have you ever tried to come up with excuses to avoid coming to Sabbath service? Or to avoid attending SSC even if you have the time to? How about to avoid coming

to RE classes, or to avoid church duties, such as cleaning or hymn singing? When we come up with excuses to avoid God, it means that we are prioritizing other things over Him. When we do this, we are doing exactly what the people in the parable were doing: we are declining His invitation.



## Linking to the Ten Basic Beliefs

2-5 Minutes

### Salvation is given by the grace of God through faith.

Salvation is something we are all invited to partake in, but we may, even unknowingly, callously decline God’s loving invitation if we are not careful. We must remember to always take God’s invitation seriously, and not let ourselves get caught up in the worries and cares of the physical world around us. We must strive to always remember: there is a better home waiting for us. We need to be ready for when God is prepared to bring us there.



## Check for Understanding

5 Minutes

### 1. What excuses did the first group of guests give for declining the banquet?

- I have just bought a field and must inspect it.
- I have just bought five pairs of oxen, and I want to test them out.
- I now have a wife, so I can't come.

### 2. Who were invited later? The poor, the crippled, the blind, and the lame.

### 3. Who do these people represent? The Gentiles—us!

### 4. What does the banquet represent? The heavenly kingdom.

### 5. Who does the host represent? God.



## Life Application

10 Minutes

### 1. You're Invited!

- Objectives:**
1. To understand the importance and necessity of accepting and taking up the invitation God has given to all of His children.
  2. To understand that we are created and loved by God.

[Hand out Life Application Worksheet #1, and go over the invitation and introduction with the students. Let them know that they have been invited by God to spend eternity with Him in His kingdom, and that this is not an invitation they should decline.]

There are many ways we can accept God’s invitation, and the least of these is spending time with God on Sabbath day. What are some other ways we can show God our acceptance of His invitation? Are there any habits in your daily life that you can change or cultivate? What about your relationship with your parents or your siblings? Perhaps there are additional things you can do to help out in church. Think of some things you think you can do, and then fill out the RSVP letter.

### 2. Excuses, Excuses, Excuses

**Objective:** To understand why we shouldn't make excuses for not accepting God's invitation to become part of His family.

[Hand out Life Application Worksheet #2. Refer to the Teacher Version for instructions and answers.]



## Activity

### Invitation Cards

10-15 Minutes

**Objective:** To give students an opportunity to hand out invitations for Sabbath service to their friends.

It's important to always remember our friends and family members around us that have not yet believed in God or have not been baptized yet. We should always be looking for opportunities to invite them to attend our services and Bible studies. Giving them a handmade card is a thoughtful way of inviting them to church, and of giving them something to keep and remind themselves of when they have the time.

#### Materials

- Invitation (see template), one copy per student
- Envelope templates or pre-made envelope, one per student
- Markers, crayons, colored pencils
- Pens, pencils, ultra-fine markers
- Glue

#### Instructions

1. Distribute one invitation and one envelope template per student.
2. Cut out the envelope templates. Fold along the dotted lines and glue to make the envelope.
3. On the invitation card, fill out the name of the person you want to invite.
4. Then, fill out the day of the week, the location, and the worship hours for Sabbath service.
5. Sign and print your name at the bottom.
6. Decorate the envelope and invitation card.

#### HOMEWORK ANSWER KEY

1. banquet
2. excuses
3. field
4. oxen
5. wife
6. The poor, the crippled, the blind, and the lame
7. The heavenly kingdom
8. God
9. By attending Sabbath service and preparing ourselves by praying for the fullness of the Holy Spirit
10. By making up excuses to avoid God

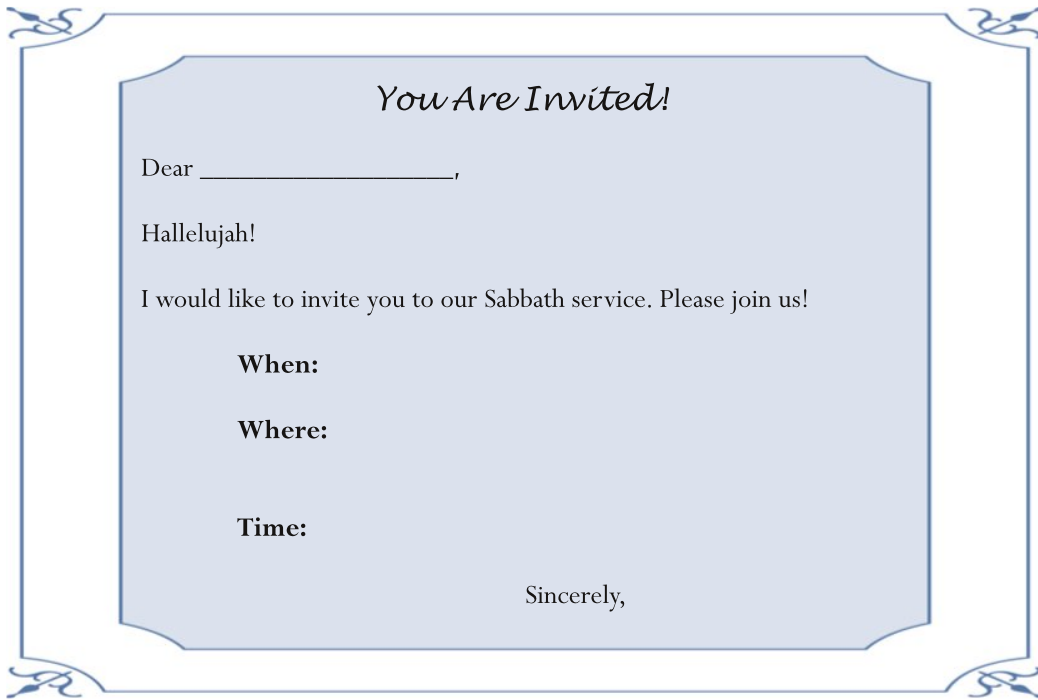

*You Are Invited!*

Dear \_\_\_\_\_,

Hallelujah!

I would like to invite you to our Sabbath service. Please join us!

**When:**

**Where:**

**Time:**

Sincerely,

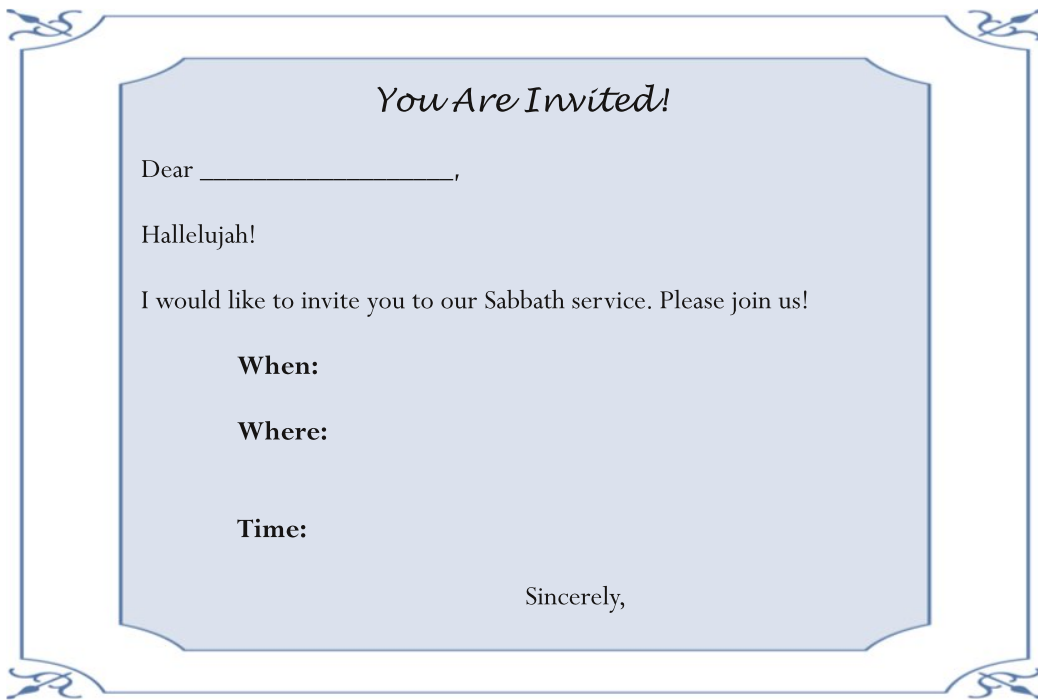

*You Are Invited!*

Dear \_\_\_\_\_,

Hallelujah!

I would like to invite you to our Sabbath service. Please join us!

**When:**

**Where:**

**Time:**

Sincerely,



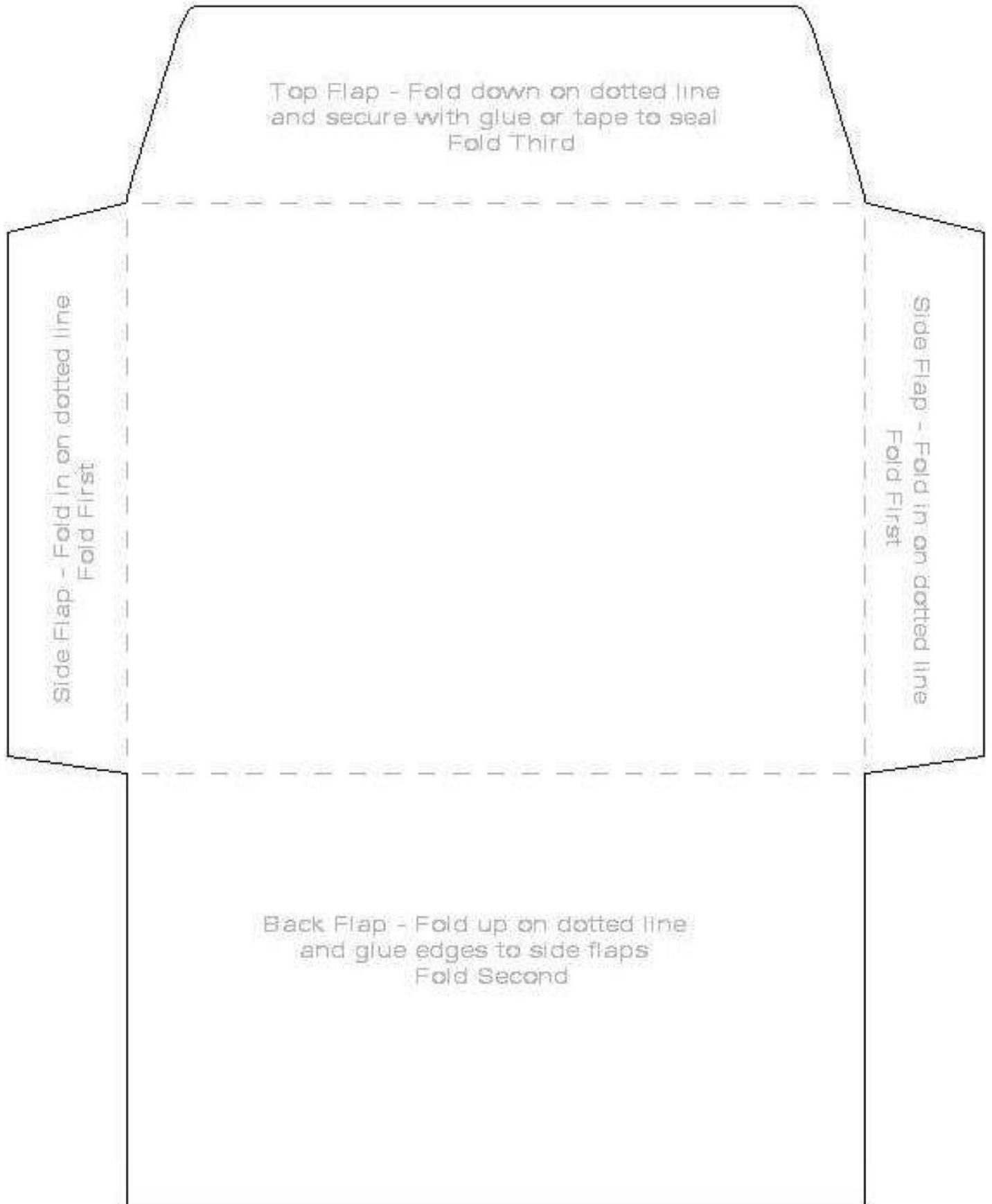

**EXCUSES, EXCUSES, EXCUSES**

**Objective:** To understand why we shouldn't make excuses for not accepting God's invitation to become part of His family.

Give the students time to read through the chart and fill out the last column of "good answers" on their worksheet. Then, once they've finished, spend time discussing their answers, and share the "God's Answer" column with them, referring to the Bible verses if you have time.

GOD'S INVITATION	EXCUSE	GOD'S ANSWER
God invites us to seek Him on Sabbath day.	I don't like going to church on Saturday morning because it's always too early in the morning for me. I like to stay home and watch cartoons. Sometimes, my friends have parties on Saturdays, and I also need to work on my schoolwork.	<p><i>Observing the Sabbath is a commandment. God shows kindness and love to all people. He wants us to rest on the Sabbath by coming to church and listening to the words of God.</i></p> <p>(Mk 2:27)</p>
God invites us to believe in His word.	I don't understand God's words. Sometimes they're confusing. Plus I am too busy to think about God and study the Bible anyway. I have too many things to do.	<p><i>Don't wait to think about being part of God's family. God's love and grace will help you every day!</i></p> <p>(Ps 55:17; 1 Chr 16:11)</p>
God invites us to pray to Him.	God knows everything; I don't need to pray to him all the time.	<p><i>Prayer is always needed when we need God's help. There are certain things that require prayer and, sometimes, even fasting and prayer.</i></p> <p>(Mk 9:29; Mt 21:22)</p>
God invites us to be baptized.	I don't want to get baptized right now. I don't like going into the water either. What's so good about it anyway? Baptism is for grown-ups. I should wait until I'm older.	<p><i>God loves children and He treats them just as important as grown-ups. He wants everyone to be part of His family. Jesus also tells us that we must be born of water and the Spirit if we want to go to heaven.</i></p> <p>(Mk 10:13-16; Jn 3:5)</p>
God invites us to spread His word.	I'm not good at preaching to others. I don't speak very well. My friends don't like to listen to my preaching. I'm afraid of being rejected when I preach.	<p><i>God wants us to preach the gospel to everyone in all places of the world. It doesn't matter if others reject us. We just move on. But we must always continue to preach.</i></p> <p>(Mt 24:14; Mt 10:14; Mk 16:15)</p>

### THE PARABLE OF THE GREAT BANQUET

**Instructions:** Summarize today's Bible story by illustrating it in the boxes below. Use eight panels to show the story in order, and then write a caption below each panel to tell the story.

**1**

---

---

**2**

---

---

**3**

---

---

**4**

---

---

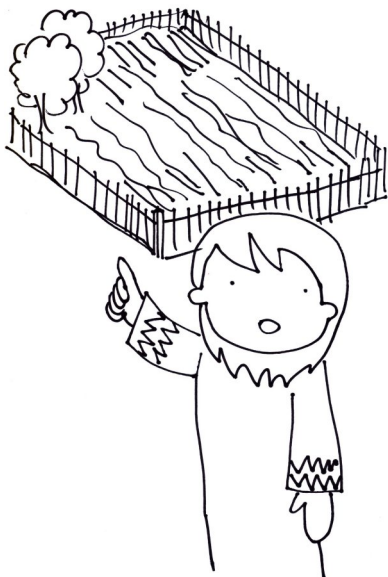

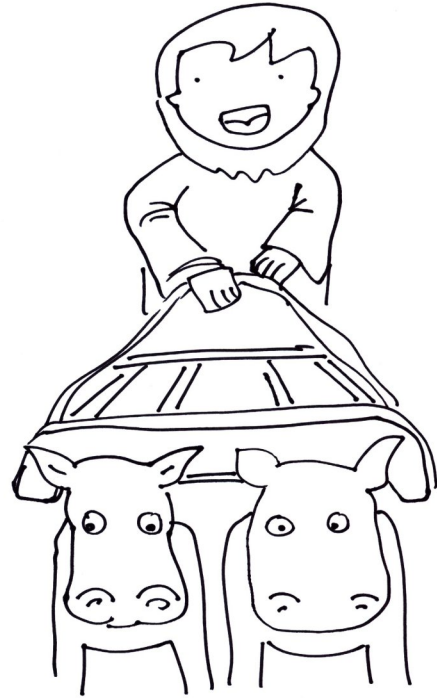

**5**

---

---

**6**

---

---

**7**

---

---

**8**

---

---

**WHAT'S SO GREAT ABOUT HEAVEN?**

God has invited us to be with Him in heaven one day. But what's so great about heaven? Why would we want to go there?

The Bible doesn't give us an abundance of details as to what heaven will be like, but it does tell us what we need to know.

HEAVEN  
is a  
Wonderful  
PLACE  
WHERE WE WILL BE  
WITH GOD  
forever

Fill in the blanks below by looking up the verses.

**1. Heaven will be a paradise. (Luke 23:43)**

"And Jesus said to him, 'Assuredly, I say to you, today you will be with Me in \_\_\_\_\_.'"

**2. Heaven will be full of spiritual joy. (Romans 14:17)**

"For the kingdom of God is not eating and drinking, but righteousness and peace and \_\_\_\_\_ in the \_\_\_\_\_."

**3. God will be with us forever. (Revelation 21:3)**

"And I heard a loud voice from heaven saying, "Behold, the tabernacle of God is with men, and He will \_\_\_\_\_, and they shall be His people. God Himself will be with them and be their God."

**4. There will be no more pain or sorrow. (Revelation 21:4)**

"And God will wipe away every \_\_\_\_\_ from their eyes; there shall be no more \_\_\_\_\_, nor sorrow, nor crying. There shall be no more \_\_\_\_\_, for the former things have passed away."

**5. Heaven is beautiful. (Revelation 21:18-21)**

"The construction of its wall was of jasper; and the city was pure \_\_\_\_\_, like clear glass. The foundations of the wall of the city were adorned with all kinds of precious stones: the first foundation was jasper, the second sapphire, the third chalcedony, the fourth emerald, the fifth sardonyx, the sixth sardius, the seventh chrysolite, the eighth beryl, the ninth topaz, the tenth chrysoprase, the eleventh jacinth, and the twelfth amethyst. The twelve gates were twelve pearls: each individual gate was of one pearl. And the street of the city was pure gold, like transparent glass."

NO MORE  
CURSE  
NO MORE  
SIN

**6. There will be no more sin. (Revelation 22:3)**

"And there shall be no more \_\_\_\_\_, but the throne of God and of the Lamb shall be in it, and His \_\_\_\_\_ servants shall serve Him."

### YOU'RE INVITED!

There are many ways we can accept God's invitation, and the least of these is spending time with God on Sabbath day. What are some other ways we can show God our acceptance of His invitation? Are there any habits in your daily life that you can change or cultivate? What about your relationship with your parents or your siblings? Perhaps there are additional things you can do to help out in church. Think of some things you think you can do, and then fill out the RSVP letter below.

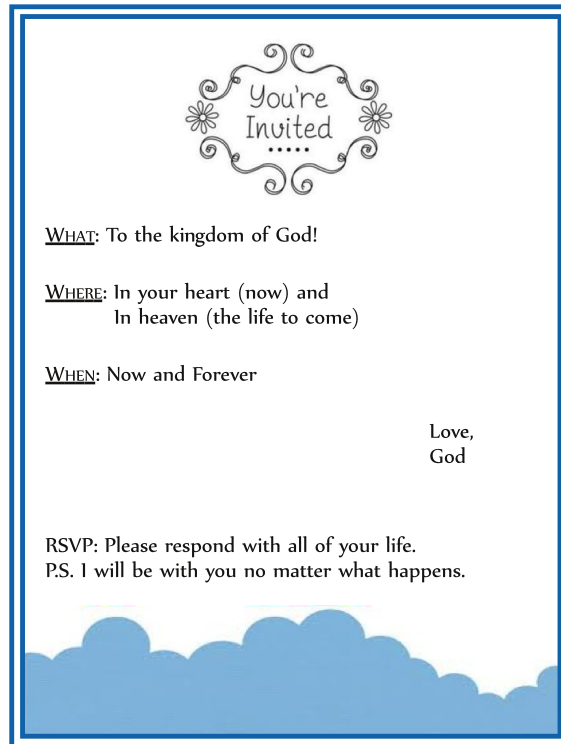

### R.S.V.P.

Dear God,

I, \_\_\_\_\_ (your name), humbly accept Your invitation to the heavenly kingdom. In acceptance of this invitation, I will gladly set aside the worries of my daily life and spend time with You on the Sabbath day. I also pray to You so that I can be filled with the Holy Spirit and be prepared for the coming banquet.

In addition to the above, I also plan to...



Yours lovingly,

\_\_\_\_\_



**EXCUSES, EXCUSES, EXCUSES**

Examine the following excuses some people may make for not accepting God's invitation to become part of His family. Then, fill in the "Good Answer" column by describing how you would answer the person if you were their friend.

GOD'S INVITATION	EXCUSE	GOOD ANSWER
<p>God invites us to seek Him on Sabbath day.</p>	<p>I don't like going to church on Saturday morning because it's always too early in the morning for me. I like to stay home and watch cartoons. Sometimes, my friends have parties on Saturdays, and I also need to work on my schoolwork.</p>	
<p>God invites us to believe in His word.</p>	<p>I don't understand God's words. Sometimes they're confusing. Plus I am too busy to think about God and study the Bible anyway. I have too many things to do.</p>	
<p>God invites us to pray to Him.</p>	<p>God knows everything; I don't need to pray to him all the time.</p>	
<p>God invites us to be baptized.</p>	<p>I don't want to get baptized right now. I don't like going into the water either. What's so good about it anyway? Baptism is for grown-ups. I should wait until I'm older.</p>	
<p>God invites us to spread His word.</p>	<p>I'm not good at preaching to others. I don't speak very well. My friends don't like to listen to my preaching. I'm afraid of being rejected when I preach.</p>	

E2 Year 2 Book 2 Lesson 11—The Parable of the Great Banquet

# Homework Assignment

Name: \_\_\_\_\_ Parent signature: \_\_\_\_\_ Date: \_\_\_\_\_

Weekly Bible Reading: \_\_\_\_\_

**Bible Reading:** Check each box when you complete that day's reading.

**Prayer:** Check each box after you pray to God that day.

	Sun	Mon	Tue	Wed	Thu	Fri	Sat
Read							
Pray							

## What I Learned from the Bible This Week

1. \_\_\_\_\_  
 \_\_\_\_\_  
 \_\_\_\_\_
2. \_\_\_\_\_  
 \_\_\_\_\_  
 \_\_\_\_\_

## Memory Verse

Please write down this week's memory verse. **(Revelation 3:20)**

\_\_\_\_\_

## Word Scramble

Unscramble the words in parentheses to fill in the blanks.

1. These people were invited to a \_\_\_\_\_ (uqteban). But, when it came time for the banquet, they gave \_\_\_\_\_ (seesuxc) as to why they couldn't attend.
2. One said, "I can't come; I've bought a \_\_\_\_\_." (ifled)
3. Another said, "I can't come; I want to try out my new \_\_\_\_\_." (neox)
4. Still another replied, "I can't come; I now have a \_\_\_\_\_." (fiwe)

## Short Answer

5. Who was invited after the servants reported the excuses given?
6. What does the banquet represent?
7. Who does the host represent?
8. How do we accept God's invitation?
9. How do we sometimes decline His invitation?

# LESSON 12

## THE SECOND COMING OF JESUS

### OBJECTIVES

1. To learn about the events of the second coming.
2. To understand the purpose of Jesus' return.
3. To learn how to prepare ourselves to meet the Lord.

### MEMORY VERSE

"Therefore you also be ready, for the Son of Man is coming at an hour you do not expect."

(Luke 12:40)

### PRAYER

1. Thank you, heavenly Father, for gathering us in Your presence on this holy Sabbath day.
2. Please open our hearts as we learn about the teachings concerning Jesus' Second Coming.
3. Please also grant us a wise and watchful heart so that we can prepare ourselves to meet You.



### Overview

#### 1. The nature of Jesus' Second Coming

- Swift and sudden
- No one will know the time or hour
- Changes will happen in heaven and on earth

#### 2. Jesus' appearance

#### 3. The purpose of Jesus' return

- To gather His elect
- To destroy the world
- To judge all men
- To welcome us into our eternal home.

#### 4. Linking to the Ten Basic Beliefs—The Second Coming of Jesus

#### 5. Life Application—Preparing Myself to Meet the Lord

#### 6. Activity—Word Search ("Jesus Will Return")



### Background Knowledge for Teachers

Jesus' Second Coming is perhaps the most anticipated event in the history of the world. Every generation of believers, including those in the New Testament, have strongly believed that Jesus will return in their lifetime. 2 Thessalonians 2:1-2 tells us, "concerning the coming of our Lord Jesus Christ and our gathering together to Him, we ask you, not to be soon shaken in mind or troubled, either by spirit or by word or by letter, as if from us, as though the day of Christ had come." Some are mistakenly frightened that they have missed the second coming. Others doubt that it will ever occur. They will say, "Where is the promise of His coming? For since the fathers fell asleep, all things continue as they were from the beginning of creation" (2 Pet 3:4). So, we must avoid both extremes: believing that the second coming has already occurred, and believing that the second coming will never occur.

Many religious figures have made guesses as to when the second coming will occur. They have all been incorrect. The Bible declares, "But of that day and hour no one knows, not even the angels of heaven, but My Father only" (Mt 24:36). The Bible does not give us the time, but instead describes several signs and events that must occur before the second coming. So, although we are to anticipate this event, we must also have a biblical understanding of it. There is no reason for setting dates or predicting times. Instead, we must live our lives as if it could happen any day, at any moment.



## Reaching Out to Your Students

On one hand, learning about the end of the world can be frightening for some students. We should remind them that anticipating the second coming can be likened to a child who is eagerly looking forward to seeing a parent or a loved one whom they have not seen for a long time. For people who do not know God, it is a terrifying moment. But for believers, it is a moment that they have longed and hoped for throughout their life of faith. It is a time of great joy and happiness when we will at last behold our God and dwell eternally with Him.

On the other hand, some students may receive the news with flippancy. Impress upon them the serious nature of this event, and the possibility that it could happen in the next minute. We must live our lives with a strange urgency, always remembering that God could appear at any moment, and that when He does, He will judge us.



## Opener

5 Minutes

Set a ringtone on your phone that can be played with a touch at any time you wish. Then, arrange a bowl of small prizes or candy somewhere in the room, numbering less than the number of students. Explain to the students that they are not to touch the prizes or candy until the ringtone goes off. When it does go off, they are allowed to grab one prize or piece of candy. Emphasize that it could go off at any time during class.

Once you have set the ringtone off—try to wait for a time when the students are not expecting it, or perhaps are working on their worksheets/activity—explain to them that the second coming will be very much like this: the time is unknown, and it will be unexpected when it does arrive. But, as long as we are watchful, we can prepare ourselves. The students who are watchful—perhaps those who kept an eye on your hand to see when you would tap your phone—will be ready for it. Make sure you give prizes to the students who were not able to get one.

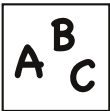

## Vocabulary

**tsunami:** a Japanese word in which “tsu” means harbor, and “nami” means wave, literally translating into “harbor wave”; a large and destructive ocean wave usually caused by an underwater earthquake  
**archangel:** the prince of angels



## Bible Discovery & Spiritual Teaching

30-35 Minutes

### FOR TEACHERS

As this lesson contains many verse references, please pace yourself accordingly and make sure the students have time to turn to each Bible verse. Perhaps have an assistant help any students who are having difficulty.

In a previous lesson, we learned about the signs of the end times, and that the end times would mark the return of Jesus—the event we call Jesus’ Second Coming. Today, we’re going to continue the topic and learn about the second coming itself, and what will happen when it occurs.

### The Nature of Jesus’ Second Coming *It Will Be Swift and Unexpected*

So, what will the second coming be like? First, we know that the Bible uses many different analogies to explain that it will be **swift and unexpected**.

### FOR TEACHERS

Please hand out Bible Discovery Worksheet #1. As you refer to each analogy and verse, please have your students fill in the blanks. The answers have been underlined in this section.

There is a passage that describes Jesus as a master who returns unexpectedly. Let’s read the passage together in Mark 13:34-37:

“It is like a man going to a far country, who left his house

and gave authority to his servants, and to each his work, and commanded the doorkeeper to watch. Watch therefore, for you do not know when the master of the house is coming—in the evening, at midnight, at the crowing of the rooster, or in the morning—lest, coming suddenly, he find you sleeping.”

Jesus here describes Himself as a man who goes on a journey. Before he departs, he leaves instructions to the servant and the doorkeeper to carry on their work and to keep watch until he returns. The servants understand that although their master is temporarily gone, they must continue to work diligently. They would not want their master to return suddenly and find them sleeping or slacking off from their duties.

Jesus is now in heaven, but like the man in the story, He will return someday. We do not know exactly when the Lord will return, but we need to stay awake spiritually by reading the Bible, praying, and obeying His will. We would not want Jesus to suddenly return and find us spiritually sleeping and enjoying the pleasures of this world.

The next verse, Revelation 3:3b, says that the second coming will be like a thief in the night. Let's read the passage together:

“Therefore if you will not watch, I will come upon you as a thief, and you will not know what hour I will come upon you.”

Usually, thieves break into houses at night when everyone is sleeping and unguarded. If someone knew ahead of time that a thief was going to break into his house, he would stay up to protect it. This teaches us that the way to be ready for Jesus' return is to be spiritually awake and ready. This means living a godly life and obeying His will. In this way, when Jesus does come, it will not happen as a complete surprise, like a thief breaking in.

#### *No One Knows the Time or Hour*

Have you ever had to wait for someone before? Perhaps a friend or a family member? When you did, you probably said when and where to meet each other. But sometimes the person you're meeting runs late, or you appear early. When this happens, you have to wait and watch for them, because you don't know when they're going to appear.

Let's turn to Mark 13:32-33.

“But of that day and hour no one knows, not even the angels in heaven, nor the Son, but only the Father. Take heed, watch and pray; for you do not know when the time is.”

Although Jesus has given us general signs to watch for

regarding His coming, He explains to us that no one will know the exact day or hour of His coming. Even the angels and the Son (Jesus Himself) do not know. Only the heavenly Father knows the exact time. Therefore, we should be careful not to be misled by people who claim that Jesus will come on a certain day or hour. These prophecies and predictions are false.

Let's also read Matthew 24:37-39. Jesus continues to say that when He comes, people will be going about their normal lives, just as in Noah's time. Do you remember what happened? All of Noah's neighbors were eating and drinking and being merry when the rains came. None of them believed Noah, and as a result, they perished in the flood. In the same way, Jesus will come in the blink of an eye, while we are going about our daily lives.

#### *Changes Will Happen in Heaven and on Earth*

When Jesus was crucified on the cross, strange and miraculous events occurred when He took His last breath and gave up His spirit.

Let's read Matthew 27:51-54 to find out what occurred.

- The veil in the temple tore in two from top to bottom.
- The earth quaked and the rocks split open.
- The graves opened and many believers who had died, resurrected, coming out of the graves and appearing before many in Jerusalem.

If such extraordinary things occurred with the death of Jesus, how much more do you think will happen during His second coming? The Bible tells us that strange and astounding things will occur on earth and in the heavens before His coming.

Let's turn to Luke 21:25-27 and read what is going to happen.

“And there will be signs in the sun, in the moon, in the stars; and on the earth distress of nations, with perplexity, the sea and the waves roaring; men's hearts failing them from fear and the expectation of those things which are coming on the earth, for the powers of heaven will be shaken. Then they will see the Son of Man coming in a cloud with power and great glory.”

How do you think people of the world will feel when they witness this? It will probably be a time of great distress, and people will probably become incredibly scared when they see what is happening.

How about you? How do you think you would feel? As believers, we should be filled with confidence and joy when we see such events, because we know that they



mark Jesus' coming, and in turn, our entry into our heavenly home where we will finally see God.

### Jesus' Appearance

Now we've learned all about the characteristics of the second coming, but what about the main event—Jesus Himself?

Let's read two verses. First, let's turn to Revelation 1:7-8.

"Behold, He is coming with the clouds, and every eye will see Him, even they who pierced Him. And all the tribes of the earth will mourn because of Him. Even so, Amen."

Second, let's read 1 Thessalonians 4:16.

"For the Lord Himself will descend from heaven with a shout, with the voice of an archangel, and with the trumpet of God. And the dead in Christ will rise first."

When the Lord Jesus first came into the world, He came as the son of a lowly carpenter. He came to serve mankind and to offer Himself up on the cross for their sins. When He appears a second time, He will no longer be a humble servant. Rather, we will see Him as He truly is: the King of kings and Lord of lords. He will appear on clouds with great power and glory and the voice of an archangel. Every eye on earth will see Him, and they will mourn because they will know that it is Jesus, and that they will have to face both judgment and destruction.

### The Purpose of Jesus' Return

#### *To Gather His Elect*

What will happen when Jesus makes His appearance? The Bible mentions several purposes of His return. First, let's continue reading the next verse, 1 Thessalonians 4:17. Now, let's turn to Matthew 24:31

These verses tell us that one of His purposes will be to gather His elect.

Do you know what "elect" refers to here? It means those who are chosen by Him. In other words, those believers who are baptized and receive the Holy Spirit are His chosen ones. When Jesus comes, He will send angels out to gather the elect from the four corners of the world. Believers who have already passed away will resurrect and be transformed into spiritual bodies. Then, those who are still alive will also be transformed, and everyone will be caught up in the clouds to meet the Lord and be with Him forever.

#### *To Destroy the World*

For His next purpose, let's turn to 2 Peter 3:10.

This verse tells us that Jesus' purpose when He returns will be to destroy the world. The world around us—and even heaven itself—will pass away, and we will live instead

in a new heavens and a new earth (v. 13).

#### *To Judge All Men*

There is a third, very important purpose for Jesus' return. Let's read Revelation 20:12-15 and 2 Corinthians 5:10.

Jesus' third purpose will be to judge all men. Our life does not end at death. After our physical death, there will be the great judgment. Every human being will stand before God and will be judged according to their works. During that time, the Book of Life will be opened, and if anyone's name is found in it, they will be saved and receive eternal life. Those who do not know God, and whose names are not found in the book, will be thrown into the lake of fire.

Besides the Book of Life, other books will be opened, which have records of each person's works. From these books, God will give to each person according to all that they have done. During that time, we will have to give account for everything we have said and done while on earth. Those who did good, loved God and men, and preached the gospel will be rewarded. However, those who lived for their own enjoyment and pleasure, and who did not follow the truth, will be punished.

#### *To Welcome Us into Our Eternal Home*

There is one more purpose for Jesus' second coming. Let's turn to Matthew 25:34. Jesus will welcome us into our eternal home.

Before ascending into heaven, Jesus told His disciples that He was going to prepare a place for them and that He will come again. When He does, He will take us with Him into our eternal home. This eternal home was being prepared for us since the foundation of the earth, and even now is still being made ready to receive us! It is difficult for us to even begin to imagine what kind of place it will be. The Bible describes it as a place that is "incorruptible," a place where God will "wipe away every tear." There will be no death, no pain, no sorrow, and no crying (Rev 21:4). All of the pain and sadness that we feel while on this earth will never exist once we get there.

### Conclusion

So, from what we learned, Jesus' Second Coming will be a very momentous event—it will probably be very scary, but it will also be a time of great joy, because it will be the time we finally get to see God. Once we finally reach that day, the hope that we had of reaching our eternal home will finally become a reality.

Although it is very difficult for us to imagine what will happen, and equally difficult for us to remember that it will happen, we must do our best to be watchful, and live as though it were to come at any moment.





## Linking to the Ten Basic Beliefs

2-5 Minutes

### The Lord's Second Coming

The Bible has given us the gift of both forewarning and instructions for Jesus' Second Coming. It is not enough to simply know that Jesus will come again—we must act upon this knowledge by living our lives as close to God's will as possible. Only by doing this can we be ready for the all-important event—and we must be ready. Because on that day, we will be judged: the righteous will receive eternal life, and the wicked will be condemned.



## Check for Understanding

5 Minutes

- 1. Who knows when the second coming will be?** No one, except God.
- 2. Is it true that as long as you are a TJC member, you will be saved?** No; we must live godly lives according to His word.
- 3. Will everyone be saved? How will everyone be judged on the last day?** No; they will be judged according to what they said and did while on earth.
- 4. What two analogies did Jesus use to describe His second coming?** It will be swift and unexpected, like a master returning home or a thief in the night.
- 5. What is the purpose of Jesus' Second Coming?** To gather the elect, destroy the world, judge mankind, and welcome us into our eternal home.



## Life Application

10 Minutes

### Preparing Myself to Meet the Lord

[Read the following section about the earthquake and tsunami that struck in 2004. Then, discuss the questions with the students.]

#### Sumatra Tsunami Kills 230,000

On December 26th of 2004, the most powerful earthquake in 40 years erupted in the Indian Ocean. After the earthquake, people thought that was it, but then they saw the 30-foot tall tsunami moving very quickly towards them. The giant wave crashed against the coast. The people ran as fast as they could to higher ground or inland, but for some, it was just too late. Tourists, fishermen, farmers, villagers were swept out to the ocean. Entire villages suddenly disappeared. Trucks, cars, motorbikes were swept around like toys. Many who survived had serious injuries and had lost everything.

The giant wave of water, which started in Sumatra, Indonesia, also caused deadly waves in a dozen other countries killing 230,000 people. Those 230,000 people didn't know what hit them. Tsunamis often strike with little or no warning. Can you imagine any event so devastating that it would kill 230,000 lives in one day?

- 1. Why did so many people die from the tsunami?**
- 2. What could have been done to prevent such a large number of deaths?**

In the same way the Sumatra Tsunami struck when the people least expected it, the Lord Jesus will also come without warning. Will Jesus find us ready and prepared for His coming, or will we be taken by surprise? In Luke 12:40, the Lord Jesus tells us, "Therefore you also be ready, for the Son of Man is coming at an hour you do not expect."

How can we prepare ourselves so that we can be ready to receive the Lord at any day and any moment?

[Hand out the Life Application worksheet, and ask students to read the scenario and answer the questions.]



## Activity

## Jesus Will Return

10-15 Minutes

Find the following words in the word search.

ANGELS  
ELECT  
HEAVEN  
POWER  
JESUS  
AWAKE

CLOUDS  
FIRE  
HOME  
PREACH  
THIEF  
BIBLE

DEEDS  
GLORY  
JUDGMENT  
PREPARE  
TRUMPET  
PRAY

H	I	S	B	H	S	A	W	A	K	E
E	C	L	O	U	D	S	S	B	A	P
A	D	M	S	O	G	L	O	R	Y	O
V	A	E	C	P	E	L	E	C	T	W
E	J	U	D	G	M	E	N	T	L	E
N	I	C	N	H	R	B	Z	R	E	R
P	R	A	Y	A	T	O	D	U	J	U
P	T	O	P	G	K	H	O	M	E	F
D	E	E	D	S	A	S	I	P	G	I
I	R	A	G	B	I	B	L	E	R	R
P	R	E	A	C	H	O	T	T	F	E

**HOMEWORK ANSWER KEY**

1. "Behold, He is coming with clouds, and every eye will see Him." (Rev 1:7a)
2. "But of that day and hour no one knows." (Mk 13:32a)
3. "Anyone not found written in the Book of Life was cast into the lake of fire." (Rev 20:15)
4. "The sun will be darkened, and the moon will not give its light." (Mt 24:29a)
5. "He will reward each according to his works." (Mt 16:27b)
6. "The day of the Lord will come as a thief in the night." (2 Pet 3:10)
7. "Then they will see the Son of Man coming in the clouds with great power and glory." (Mk 13:26)
8. "Come [...] inherit the kingdom prepared for you... from the foundation of the world." (Mt 25:34b)
9. We must live a godly life and be watchful by consistently praying, reading the Bible, and doing God's will.

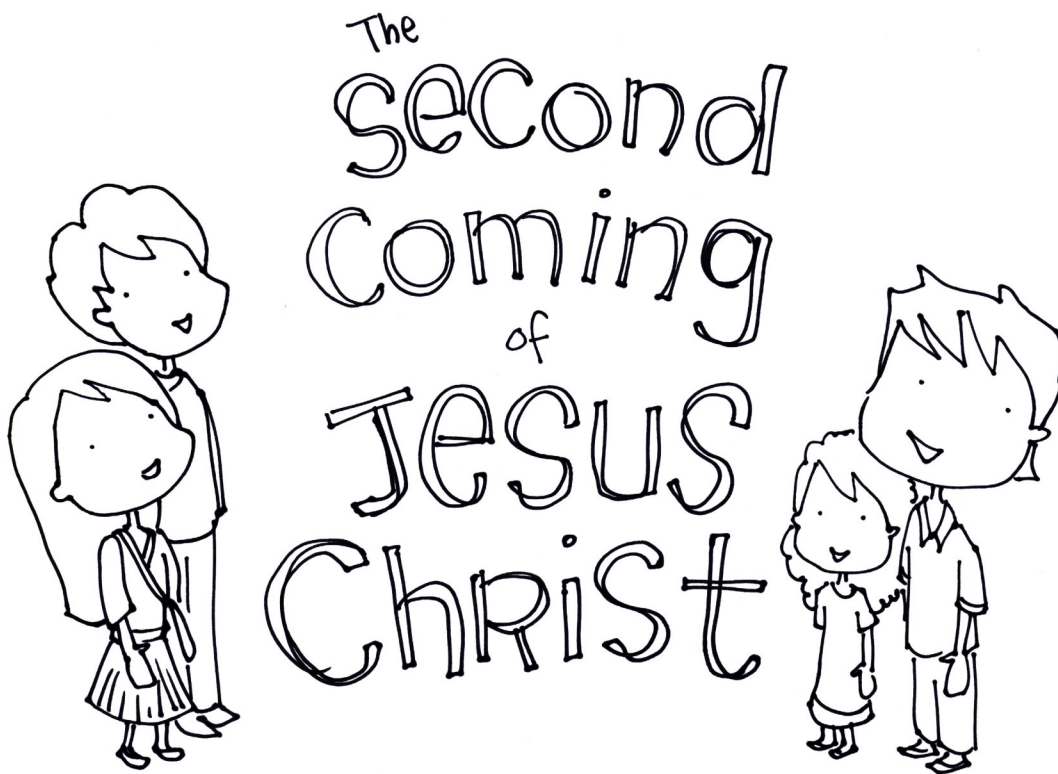

### Part A: The Nature of Jesus' Second Coming

What will Jesus' coming be like?

1. The Bible uses different analogies to describe it as swift and unexpected.

a. It will be like a \_\_\_\_\_ who returns \_\_\_\_\_.

(Mark 13:34-37)

"It is like a \_\_\_\_\_ going to a \_\_\_\_\_, who left his \_\_\_\_\_ and gave \_\_\_\_\_ to his \_\_\_\_\_, and to each his \_\_\_\_\_, and commanded the doorkeeper to \_\_\_\_\_. \_\_\_\_\_ therefore, for you \_\_\_\_\_ when the master of the house is coming—in the evening, at midnight, at the crowing of the rooster, or in the morning, lest, \_\_\_\_\_, he find you \_\_\_\_\_."

b. It will be like a \_\_\_\_\_ in the \_\_\_\_\_.

(Revelations 3:3b)

"Therefore if you will not \_\_\_\_\_, I will come upon you as a \_\_\_\_\_, and you will \_\_\_\_\_ what \_\_\_\_\_ I will come upon you."

2. The Bible says that no one knows the time or hour.

(Mark 13:32)

"But of that \_\_\_\_\_ and \_\_\_\_\_ no one \_\_\_\_\_, not even the \_\_\_\_\_ in \_\_\_\_\_, nor the \_\_\_\_\_, but only the \_\_\_\_\_. Take heed, watch and pray; for you do not know when the time is."

3. When it comes, there will be changes in heaven and on earth.

(Luke 21:25-28)

"And there will be \_\_\_\_\_ in the \_\_\_\_\_, in the \_\_\_\_\_, in the \_\_\_\_\_; and on the earth distress of nations, with perplexity, the \_\_\_\_\_ and the \_\_\_\_\_; men's \_\_\_\_\_ failing them from \_\_\_\_\_ and the expectation of those things which are coming on the earth, for the powers of heaven will be shaken. Then they will see the \_\_\_\_\_ of \_\_\_\_\_ coming in a \_\_\_\_\_ with power and \_\_\_\_\_."

### Part B: Jesus' Appearance

What will happen when Jesus comes?

(Revelation 1:7-8)

"Behold, He is \_\_\_\_\_ with the \_\_\_\_\_, and \_\_\_\_\_ will \_\_\_\_\_ Him, even they who \_\_\_\_\_ Him. And all the tribes of the earth will \_\_\_\_\_ because of Him. Even so, Amen."

(1 Thessalonians 4:16)

"For the Lord Himself will \_\_\_\_\_ from \_\_\_\_\_ with a \_\_\_\_\_, with the voice of an \_\_\_\_\_, and with the \_\_\_\_\_ of \_\_\_\_\_. And the dead in Christ will rise first."

### Part C: The Purpose of Jesus' Return

Turn to the following verses to find out what Jesus will do when He returns.

1. Matthew 24:31 - To \_\_\_\_\_ His \_\_\_\_\_.
2. 2 Peter 3:10 - To \_\_\_\_\_ the \_\_\_\_\_.
3. Revelation 20:11-15 - To \_\_\_\_\_ all \_\_\_\_\_.
4. Matthew 25:34 - To \_\_\_\_\_ us into our \_\_\_\_\_.

## Preparing Myself to Meet the Lord

### Sumatra Tsunami Kills 230,000

On December 26th of 2004, the most powerful earthquake in 40 years erupted in the Indian Ocean. After the earthquake, people thought that was it, but then they saw the 30-foot tall tsunami moving very quickly towards them. The giant wave crashed against the coast. The people ran as fast as they could to higher ground or inland, but for some, it was just too late. Tourists, fishermen, farmers, villagers were swept out to the ocean. Entire villages suddenly disappeared. Trucks, cars, motorbikes were swept around like toys. Many who survived had serious injuries and had lost everything.

The giant wave of water, which started in Sumatra, Indonesia, also caused deadly waves in a dozen other countries killing 230,000 people. Those 230,000 people didn't know what hit them. Tsunamis often strike with little or no warning. Can you imagine any event so devastating that it would kill 230,000 lives in one day?

1. Why did so many people die from the tsunami?
2. What could have been done to prevent such a large number of deaths?

In the same way the Sumatra Tsunami struck when the people least expected it, the Lord Jesus will also come without warning. Will Jesus find us ready and prepared for His coming, or will we be taken by surprise? In Luke 12:40, the Lord Jesus tells us, "Therefore you also be ready, for the Son of Man is coming at an hour you do not expect."

**How can we prepare ourselves so that we can be ready to receive the Lord at any day and any moment?**





**Read the following story about a boy named Brian.**

Brian comes from a wealthy family with successful parents. He has been told that he needs to work hard at school so that he can get into a reputable college, find a high-paying job, and lead a comfortable life. He has watched his parents work hard and seen the fruit of their labor. He decides that his goal is to work hard to make it to the top. Besides his academic studies, Brian has a lot of close friends at school and enjoys being on the basketball team, in orchestra, and on the debate team with them.

In church, things are different. He just doesn't fit in. His peers spend too much time going to church events, RE classes, and services. He much prefers hanging out with his school buddies, playing video games, skateboarding, and watching movies.

Brian only attends the Saturday morning service now, but he often dozes off during the sermons. He didn't used to be like this. He simply drifted further and further from God. In fact, he doesn't really know if there is a God anymore. He finds that his prayers are getting weaker and weaker. A few years ago, he received the Holy Spirit at a Student Spiritual Convocation, but he's afraid to face the fact that he may have lost the Holy Spirit, so he doesn't pray. Brian feels that he doesn't really need God. He's seen from his parents' example how, through hard work, a person can accomplish a good life, success, and material prosperity. Brian feels that living in the present is what's important. He only lives once, so he's going to enjoy life to the fullest. The future? He's not going to worry about that now.

**Are YOU Ready?**

It is the Last Day and Brian is standing face to face with the Lord Jesus, and Jesus has a few questions for him. Write down Brian's answers to His questions. Then, read the Bible verses and write how God wants us to live for Him.

1. Was I first place in your heart?

Matthew 22:37-38

2. Were you kind and caring to others?

Matthew 25:34-36

3. Did you spend time praying and reading the Bible?

2 Timothy 3:15; 1 Timothy 4:8

4. Did you spread the gospel to others around you?

Matthew 24:14

5. Did you use the talents and gifts I gave you to serve the church and others?

Matthew 25:20-21





## E2 Year 2 Book 2 Lesson 12—The Second Coming of Jesus

# Homework Assignment

Name: \_\_\_\_\_ Parent signature: \_\_\_\_\_ Date: \_\_\_\_\_

**Weekly Bible Reading:** \_\_\_\_\_

**Bible Reading:** Check each box when you complete that day's reading.

**Prayer:** Check each box after you pray to God that day.

	Sun	Mon	Tue	Wed	Thu	Fri	Sat
Read							
Pray							

### What I Learned from the Bible This Week

1. \_\_\_\_\_  
\_\_\_\_\_
2. \_\_\_\_\_  
\_\_\_\_\_

### Memory Verse

Please write down this week's memory verse. **(Luke 12:40)**

\_\_\_\_\_

**Draw a line to match up the phrases of each Bible verse.**

- |  |   |
|--|---|
| 1. "Behold, He is coming with clouds...                        | ...was cast into the lake of fire." (Rev 20:15)       |
| 2. "But of that day and hour...                                | ...according to his works." (Mt 16:27b)               |
| 3. "Anyone not found written in the Book of Life...            | ...from the foundation of the world." (Mt 25:34b)     |
| 4. "The sun will be darkened...                                | ...with great power and glory." (Mk 13:26)            |
| 5. "He will reward each..."                                    | ...and the moon will not give its light." (Mt 24:29a) |
| 6. "The day of the Lord will come..."                          | ...and every eye will see Him." (Rev 1:7a)            |
| 7. "Then they will see the Son of Man coming in the clouds..." | ...as a thief in the night." (2 Pet 3:10)             |
| 8. "Come [...] inherit the kingdom prepared for you..."        | ...no one knows." (Mk 13:32a)                         |

**Short Answer**

9. What are some of the things that you need to do to get ready for Jesus' return?

# REVIEW

Teachers can reference this lesson to give them some ideas about questions to ask during a review lesson. The review can be in any format: a standard written quiz, a Jeopardy-style game, a board game, etc. The important thing is to give the students a chance to review all the things they have learned in the past quarter. You can draw your review questions from the **Check for Understanding** sections in each lesson, as well as the **homework assignments**. Remember to include some **life application questions** to allow the students to apply what they have learned to their lives.

## ANSWER KEY

### I. Memory Verse Fill In the Blank

1. fellowship, prayers
2. commandment, one another
3. ceasing, thanks
4. earnestly, vigilant
5. everything, requests
6. forgive, trespasses
7. ask, will
8. mercy, grace
9. always, worthy
10. Watch, hour
11. hears, opens
12. ready, expect

### II. Four Great Prayers

**Jacob:** mercy; He prayed for mercy from his brother so that his brother would not hurt his family. God promised that his descendants would be many.

**Moses:** affliction; He prayed to God when the people kept complaining to him about different things. God gave His Spirit to seventy elders to help this person lead the people.

**Hannah:** special need; She prayed to God for a son because she was barren. God granted her a son, and she dedicated him to God's service.

**Solomon:** wisdom; Instead of money and honor, he prayed for wisdom to lead God's people. God granted him wisdom, as well as riches and honor, for as long as he followed Him.

### III. Accept God's Invitation and Prepare Yourself

#### A. *The Parable of the Great Banquet*

9, 4, 10, 3, 6, 1, 8, 5, 2, 7

#### *The Parable of the Ten Virgins*

8, 4, 2, 7, 10, 3, 5, 1, 9, 6

- B. They teach us that we must accept His invitation to experience eternal life with Him in heaven, and that we must do so by preparing for His arrival. We do not know when He will return, so we must be prepared at all times. If we are not prepared when He arrives, no matter how much we beg or plead, He will not let us into His kingdom.

### IV. Short Answer and Life Application

1. It is important to follow God's will because God knows what is best for us. He is omniscient, and He also loves us very much. For that reason, He would never ask us to do anything that is bad or anything that will harm us. On the contrary, everything He asks us to do will always help us in some way, whether it is to become more mature spiritually or to gain wisdom to discern right from wrong. It is important that we always strive to follow His will, even when it seems impossible.
2. We can look out for our brothers and sisters who are in need; we can follow the examples that Jesus set and care for others; we can practice small acts of kindness to everyone that we meet; we can share God's words with others.
3. James is telling us that our faith alone is not enough. We cannot say we have faith in God, but turn a blind eye to someone in need. Rather, we need to both have faith in God and put His words into action by opening our hearts to others in need. It is important to put our faith into action, because not only will it allow others to see God in us, it will show God that we love Him.
4. The early believers shared all they had, sold their belongings to give to the needy, broke bread together daily, had gladness and simplicity in their hearts, praised God, gained favor among the people, and continued to grow in number.
5. Answers may vary. These are the various teachings from the Lord's Prayer:
  - We have a relationship with a heavenly Father.
  - God's name is holy, and we must praise it.
  - Everything is done with a purpose in our lives.
  - God will look after our needs.
  - We owe God, and we must forgive others first.
  - We must flee from what tempts us and rely on the power of the Holy Spirit.
  - We are safe in God's kingdom.
6. Answers may vary.

## I. Memory Verse Fill In the Blank

**Instructions:** Complete the memory verses by filling the blanks in with the missing words.

fellowship	worthy	thanks	ask	hour	hears
grace	expect	one another	always	prayers	ceasing
everything	earnestly	requests	opens	trespasses	commandment
ready	forgive	will	mercy	watch	vigilant

1. "And they continued steadfastly in the apostles' doctrine and \_\_\_\_\_, in the breaking of bread, and in \_\_\_\_\_." (Acts 2:42)
2. "This is My \_\_\_\_\_, that you love \_\_\_\_\_ as I have loved you." (John 15:12)
3. "Rejoice always; pray without \_\_\_\_\_; in everything give \_\_\_\_\_, for this is the will of God in Christ Jesus for you." (1 Thessalonians 5:16-18)
4. "Continue \_\_\_\_\_ in prayer, being \_\_\_\_\_ in it with thanksgiving." (Colossians 4:2)
5. "Be anxious for nothing, but in \_\_\_\_\_ by prayer and supplication, with thanksgiving, let your \_\_\_\_\_ be made known to God." (Philippians 4:6)
6. "For if you \_\_\_\_\_ men their \_\_\_\_\_, your heavenly Father will also forgive you. But if you do not forgive men their trespasses, neither will your Father forgive your trespasses." (Matthew 6:14-15)
7. "Now this is the confidence that we have in Him, that if we \_\_\_\_\_ anything according to His \_\_\_\_\_, He hears us." (1 John 5:14)
8. "Let us therefore come boldly to the throne of grace, that we may obtain \_\_\_\_\_ and find \_\_\_\_\_ to help in time of need." (Hebrews 4:16)
9. "Watch therefore, and pray \_\_\_\_\_ that you may be counted \_\_\_\_\_ to escape all these things that will come to pass, and to stand before the Son of Man." (Luke 21:36)
10. "\_\_\_\_\_ therefore, for you know neither the day nor the \_\_\_\_\_ in which the Son of Man is coming." (Matthew 25:13)
11. "Behold, I stand at the door and knock. If anyone \_\_\_\_\_ My voice and \_\_\_\_\_ the door, I will come in to him and dine with him, and he with Me." (Revelation 3:20)
12. "Therefore you also be \_\_\_\_\_, for the Son of Man is coming at an hour you do not \_\_\_\_\_." (Luke 12:40)

## II. Four Great Prayers

**Instructions:** Look at the illustrations below. Using lines, connect each illustration with the type of prayer the person is making, the reason the person is praying, and God's answer to the prayer.



Jacob

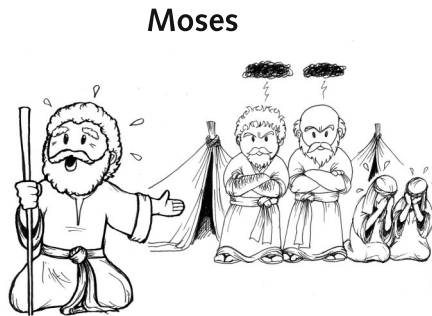

Moses

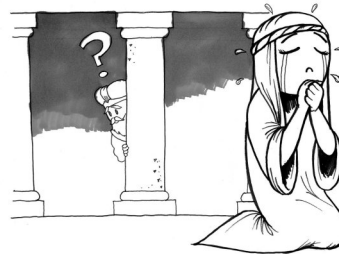

Hannah



Solomon

Special Need

Wisdom

Affliction

Mercy

He prayed to God when the people kept complaining to him about different things.

She prayed to God for a son because she was barren.

Instead of money and honor, he prayed for wisdom to lead God's people.

He prayed for mercy from his brother so that his brother would not hurt his family.

*God granted him wisdom, as well as riches and honor, for as long as he followed Him.*

*God gave His Spirit to seventy elders to help this person lead the people.*

*God granted her a son, and she dedicated him to God's service.*

*God promised that his descendants would be many.*

### III. Accept God's Invitation and Prepare Yourself

A. Below are two parables, each of which have been mixed up. Put them back in the correct ordering by numbering them from 1-10.

#### The Parable of the Great Banquet

- \_\_\_\_\_ He sent his servant to the highways and hedges to invite guests.
- \_\_\_\_\_ The guest declined, saying, "I need to test the five oxen I bought recently."
- \_\_\_\_\_ The man said that the people who refused would not be able to attend the banquet.
- \_\_\_\_\_ The guest declined, saying, "I must go see a piece of land that I just bought."
- \_\_\_\_\_ Upset that everyone refused, the man decided to invite others instead.
- \_\_\_\_\_ A man sent his servant to invite many people to come to his great banquet.
- \_\_\_\_\_ The servant went to the streets, and then came back, telling his master that there was still more room.
- \_\_\_\_\_ The guest declined, saying, "I now have a wife, so I cannot attend."
- \_\_\_\_\_ All the guests gave excuses for why they couldn't attend.
- \_\_\_\_\_ He sent his servant to the streets to invite the poor, maimed, lame, and blind.

#### The Parable of the Ten Virgins

- \_\_\_\_\_ The door to the wedding was shut.
- \_\_\_\_\_ The ten virgins heard that the groom would arrive soon.
- \_\_\_\_\_ The wise virgins brought oil; the foolish virgins did not.
- \_\_\_\_\_ The wise virgins greeted the groom as the foolish virgins went to buy oil.
- \_\_\_\_\_ The groom turned them away, saying, "Assuredly, I say to you, I do not know you."
- \_\_\_\_\_ While they waited for the groom, the ten virgins slept.
- \_\_\_\_\_ The ten virgins woke up and trimmed their lamps.
- \_\_\_\_\_ The ten virgins took lamps and prepared to greet the groom.
- \_\_\_\_\_ The foolish virgins returned and knocked on the door to the wedding.
- \_\_\_\_\_ The foolish virgins asked the wise virgins for oil, but they refused.

B. What do these two parables teach us about God and His kingdom? Why is it important to be prepared?

---

---

---

---

---

## Short Answer and Life Application

**Instructions:** Answer the questions.

**1. Follow God's Will**

Instead of taking Paul's affliction away, God gave him the strength to endure it because it was His will. Why is it important for us to follow God's will, even when it is difficult?

---

---

---

**2. We Can Help the Church**

We learned that it is important to help the church when we can. What are some different ways you can help the church?

---

---

---

**3. Put Faith into Action**

What does it mean in the Book of James when it says, "faith without works is dead"? Why is it important to put our faith into action?

---

---

---

**4. The Church**

We are all part of one body, the church. What are some things the early believers did together?

---

---

---

---

**5. Prayer**

A. Jesus taught us the Lord's Prayer to help us. Choose one line from the Lord's Prayer, write it out, and then explain how it applies to you.

---

---

---

---

B. There are many different types of prayer. Some types are praise, thanksgiving, confession, petition, or intercession. Choose one type and write a short prayer to God.

---

---

---

---



For you yourselves know perfectly that the day of the Lord so comes as a thief in the night.

**1 Thessalonians 5:2**



*Preparing for  
the Kingdom of Heaven*

**Elementary 2**

Year 2 Book 2

**General Assembly of True Jesus Church**

21225 Bloomfield Avenue  
Lakewood, CA 90715 USA